



# GEBWELL

Product Catalogue



# Gebwell – Pure heat

**Gebwell Ltd. specializes in environmentally friendly heating and cooling solutions. All the products are designed and manufactured in Finland, in Leppävirta. The knowhow we have gathered during decades in the heating industry can be seen in our products as functionality and durability. We invest in modern technical product features. When acquiring your heating system from a Gebwell dealer, you will get it installed in place.**

## Ground source heat

Ground source heat is heat energy from the sun which accumulates and is stored in the ground. Using a heat pump system, this energy can be utilized to heat buildings and domestic water. It's free and within everyone's reach – you just need the right equipment to access and utilize it.

Ground source heat is clean and renewable energy. It doesn't cause any carbon dioxide or particle emissions which accelerate global warming, and is therefore an ecological form of heating.

## Savings in heating costs

In addition to saving nature, ground source heat can also save you money. By making a one-time investment in a ground source heat system, you will permanently reduce your heating costs. A heat pump produces at least three times more thermal energy than the energy it consumes.

Ground source heating can permanently reduce your heating costs by up to 75%. At the same time, you can protect yourself from fluctuation in the price of energy. Ground source heating is a very sensible investment in the future.

## Gebwell heat pumps

- Designed and manufactured in Finland
- Energy efficient
- Carefree to use
- Cooling possibility

## District heating

District heating is the most common heating method used in towns and cities, with its benefits including ease of use, reliability and wide availability. Gebwell's equipment can provide you with district heating in a reliable and flexible manner.

## Save energy, save the environment

For instance, in Finland 80% of district heating is produced through combined production with electricity power plant. The plant's excess condensing heat is used in district heating networks. In doing so, the plant's efficiency is increased and lots of energy is saved.

Environmental emissions from combined production are approximately 30% lower than when the production of energy and heat take place in separate production facilities. It is a widely recognized manner of protecting the climate and the development of combined production is estimated to be the greatest single method of reducing greenhouse emissions.

## Gebwell G-Power® district heating substations

- Designed and manufactured in Finland\*
- Energy efficient
- Carefree to use
- Space saving, compact design



Gebwell Ltd and its partners received the highest recognition in the European heat pump industry – the Next Generation Heat Pump award!

# Table of contents

Gebwell Aries ground source heat pump	4
Gebwell G-Eco® Core heat pump	5
Gebwell G-Eco® Core 80 heat pump	6
Gebwell Taurus EVIC heat pump	7
Gebwell Taurus Inverter Pro heat pump	8
Gebwell G-Eco® Pro heat pump	9
<b>Gebwell Heat Pump Accessories</b>	
Installation set for ground source heat pump	10
Cooling supplies for installation set	10
Heating pump extension for installation set	10
Gebwell Cool cooling convector	11
Collector valve group	11
Change-over valve set	12
Circulation pump sets for domestic water	12
DHW shunt	12
Heating control group	13
Automation accessories – Gebwell Smart heat pumps	14
<b>Gebwell G-Energy® accumulator tanks</b>	
G-Energy 300 Buffer Tank	16
Gebwell G-Energy DHW buffer tank	17
G-Energy Buffer Tank	18
G-Energy SV and PW Buffer Tank	19
G-Energy Cooling Buffer Tank	20
G-Energy Coil Water Heater	21
G-Energy Custom Accumulator	22
Gebwell KVL300 hot water heater	23
Domestic hot water coil	24
Electric immersion heater	24
GW Electric Boiler EP BL	25
<b>Gebwell G-Power district heating substations</b>	
Gebwell G-Power district heating substation	27
Gebwell G-Power substation unit for detached houses	28
Gebwell G-Power Smart district heating substation	30
Gebwell district cooling substation	31
Gebwell G-Power Compact district heating substation	32
GebFilter side stream filter	34
GebVent Air and Dirt Separators	34

# Gebwell Aries ground source heat pump

- inverter ground source heat pump for detached and semi-detached houses

The advanced Aries ground source heat pump comes with a frequency-controlled compressor and completely new automation. Aries is also connected to the factory as a standard.

The power of Aries's variable-speed compressor is adjusted based on the power needed at the property. Thanks to the inverter control, the heat pump always operates at the correct power, optimising the heating output depending on the heating needs.

Aries is linked to a cloud service as a standard, which means that the manufacturer can check the system status, if needed. The cloud service also enables the remote monitoring and control of the pump.

Aries is controlled with a smart device application. The user interface can be used to monitor and adjust the heat pump through the WLAN established by the heat pump or even remotely via 4G/5G. Remote access is currently free for now, but will later become

subject to a charge.

In future, the operating data stored in the cloud service can be used for purposes such as heating optimization and preventive maintenance, or even considering weather forecasts in heating programming.

Aries heat pump is also available without built-in accumulator, model Aries 12C.

- Manufactured in Finland
- Energy efficient
- Advanced automation
- Remote connection to the manufacturer

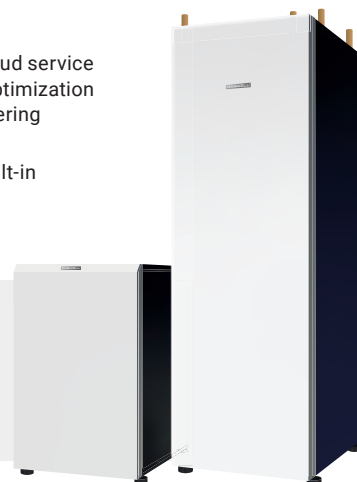

		Aries 6	Aries 12	Aries 12C
GTIN		6415853626040	6415853626149	6415853626491
Power values (according to EN 14511)				
Heating output (0°/35° and 0°/55°)	kW	1.5-7.3 and 1.3-6.7	2.6-11.8 and 2.3-11.1	2.6-11.8 and 2.3-11.1
Cooling output (0°/35° and 0°/55°)	kW	1.6-5.6 and 1.3-4.6	1.9-9.2 and 2.2-7.3	1.9-9.2 and 2.2-7.3
Electrical power (0°/35° and 0°/55°)	kW	0.4-1.7 and 0.7-2.2	0.7-2.7 and 1.1-4.0	0.7-2.7 and 1.1-4.0
Rated heating output (0°/35° and 0°/55°)	kW	3.8 and 3.5	6.7 and 6.2	6.7 and 6.2
Rated electrical power (0°/35° and 0°/55°)	kW	0.8 and 1.11	1.4 and 1.7	1.4 and 1.7
COP (0°/35° and 0°/55°)		4.8 and 3.1	4.8 and 2.9	4.8 and 2.9
SCOP (0°/35° and 0°/55°, according to EN14825)		5.6 and 4.2	5.8 and 4.3	5.8 and 4.3
The system's energy efficiency class, intermediate climate, underfloor heating		<b>A+++</b>	<b>A+++</b>	<b>A+++</b>
Heating circuit rated flow	l/s	0.13	0.23	0.23
Brine		Denatured ethanol 25-30%		
Brine flow	l/s	0.07 - 0.34	0.16 - 0.55	0.16 - 0.55
Maximum allowed external pressure loss at the brine rated flow	kPa	68 (0.19 l/s)	110 (0.34 l/s)	110 (0.34 l/s)
Heating system / Brine circuit maximum operating pressure (consider network pressure)	bar	6 / 6	6 / 6	6 / 6
Domestic water accumulator maximum operating pressure	bar	10	10	10
Heating water maximum output temperature	°C	65	65	65
Operational temperature, collector	°C	-5... +20	-5... +20	-5... +20
Compressor		Twin rotary (frequency-controlled)		
Frequency converter		yes		
Built-in heating pump		yes (frequency converter)		
Built-in source pump		yes (frequency converter)		
Electrical connection through a plug		yes, 400 VAC, 3L+N+PE, 50 Hz		
Contains fluorinated greenhouse gases		yes	yes	yes
Hermetically sealed		yes	yes	yes
Refrigerant		R410A	R410A	R410A
GWP (Global Warming Potential)		2088	2088	2088
Refrigerant charge	kg	0.92	1.42	1.42
CO <sub>2</sub> equivalence	ton CO <sub>2</sub> e	1,920	2,965	2,965
Built-in electric immersion heater can be connected	kW	2 / 4 / 6	2 / 4 / 6	2 / 4 / 6
Operating current of the protective device	A	3 x 16	3 x 20	3 x 20
Connections:				
Heating pipe	mm	22	28	28
Collector	mm	28	28	28
Domestic water	mm	22	22	-
Sound power level (L <sub>WA</sub> )	dB	34-43	36-47	36-47
Dimensions				
External dimensions (depth x width x height)	mm	660 x 600 x 1800	660 x 600 x 1800	830 x 640 x 970
Weight	kg	181	190	165
Hot water accumulator (domestic water/heating)	l	185 / 7	185 / 7	no built-in accumulator

\* Levelling feet 40 - 60 mm

# Gebwell G-Eco<sup>®</sup> Core heat pump

– inverter heat pump with natural refrigerant

Gebwell G-Eco Core is a powerful IoT inverter heat pump that uses the eco-friendly R290 refrigerant. R290 has a minimal impact on global warming compared to traditional hydrofluorocarbon (HFC) refrigerants. R290 refrigerant has a GWP of only 0.02 and an ODP of 0.

Gebwell G-Eco Core is capable of adjusting to the building's energy needs year round thanks to its inverter-controlled compressor. Continuously variable inverter control ensures that the heat output matches the network's requirements exactly without over or underheating, minimising your heating bills.

G-Eco Core is connected to the manufacturer's Gebwell Smart cloud service, allowing the heat pump to be controlled remotely through the browser-based Hub. Your maintenance company can view the status of the heating system and adjust heating settings remotely without having to send an engineer on site, saving time and money.

The remote connection also makes updating the heat pump's controller easy. Data stored in

the cloud service helps the manufacturer implement continuous improvements.

Compared to a mechanical valve, an electronic expansion valve is better suited to inverter control, allowing the heat pump to operate at optimal efficiency.

G-Eco Core's compressor unit is completely isolated and produces minimal running noise. The G-Eco Core heat pump is designed specifically for R290 refrigerant.

- Manufactured in Finland
- Continuously adjustable heating output
- Electronic expansion valve
- Controller with IoT features
- Learning and evolving system
- Monitoring and control also possible remotely through the Gebwell Smart Hub



		G-Eco Core 40
GTIN		6430079400762
Power values (EN 14511)		
Heating output (0°/35° and 0°/55°)	kW	10.5 – 39.4 and 8.7 – 38.7
Cooling output (0°/35° and 0°/55°)	kW	8.9 – 31.4 and 6.4 – 26.3
Electrical power (0°/35° and 0°/55°)	kW	2.2 – 10.6 and 3.2 – 13.7
Maximum input power	kW	20
Maximum operating current	A	37
COP (0°/35° and 0°/55°, 50 hz, EN 14511)		4.6 and 3.1
SCOP (0°/35° and 0°/55°, EN 14825)		5.1 and 4.1
The system's energy efficiency class, intermediate climate, underfloor heating		<b>A+++</b>
Charge circuit flow (0/35, 30–110 hz, delta T 5, water)	l/s	0.5 – 1.9
Brine flow (0/35, 30–110 hz, delta T 3, ethanol-water 28%)	l/s	0.7 – 2.4
Brine		Denatured ethanol 25–30 wt-%
Maximum allowed external pressure loss, with brine rated flow	kPa	100 (2.5 l/s)
Heating system / brine circuit maximum operating pressure (consider network pressure)	bar	10/10
Heating water maximum output temperature	°C	+75
Operational temperature, collector	°C	-10... +20 (+30)*
Compressor		Scroll (frequency controlled)
Frequency converter, regulation value	hz	30–110
Built-in heating pump		yes (frequency converter)
Built-in source pump		yes (frequency converter)
Electrical connection		400 VAC, 3L+N+PE, 50 Hz
Hermetically sealed		yes
Refrigerant		R290
GWP (global warming potential)		0.02
Refrigerant charge	kg	1.8
CO2 equivalence - tonnes CO2e	ton CO <sub>2</sub> e	0.000036
Operating current of the protective device	A	3 x 40
Sound level (measured according to EN 12102 and EN 3741, 0/35, at the compressor's minimum and maximum speeds)	dB(A)	45 – 54
Connections		
Heating network		G1 1/2" it
Collector		G1 1/2" it
Ventilation	mm	125
External dimensions (depth x width x height)	mm	850 x 690 x 1850
Weight	kg	380

\* temporary exceedance allowed  
v3-9 2026

# Gebwell G-Eco<sup>®</sup> Core 80 heat pump

– commercial heat pump with natural refrigerant

Gebwell G-Eco Core 80 is a commercial heat pump that uses R290 refrigerant (GWP 0.02). The compressor is designed for R290 refrigerant, and the carefully sound-insulated chassis ensures very quiet operation.

The unit can be remotely monitored and controlled via the web-based Gebwell Smart Hub service, where the unit's operation, key measurement values and alarms can be monitored, and settings adjusted remotely.

The heat pump is equipped with an easy-to-use touchscreen for local control. The touchscreen also includes a guided commissioning function. The heat pump is prepared for a Modbus connection to building automation. Up to 12 units can be connected in cascade to increase total system capacity.

- Designed and manufactured in Finland
- R290 refrigerant, GWP 0.02
- Wide operating range for the collector circuit, -10 to +30 °C
- Stepless inverter control
- High supply temperature, up to +75 °C
- Remote monitoring and control via Gebwell Smart Hub
- Touchscreen with guided commissioning
- Can be connected to building automation
- Up to 12 units in cascade

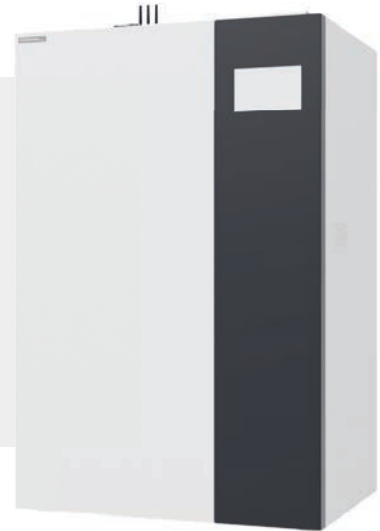

		G-Eco Core 80
GTIN		6430079400786
Power values (EN 14511)		
Heating output (0°/35° and 0°/55°) <sup>1</sup>	kW	24.6 – 86.6 and 23.7 – 79.2
Cooling output (0°/35° and 0°/55°) <sup>1</sup>	kW	20.0 – 64.0 and 17.8 – 53.0
Electrical power (0°/35° and 0°/55°) <sup>1</sup>	kW	8.0 and 11.7
Maximum input power	kW	38.7
Maximum operating current	A	69.0
COP (0°/35° and 0°/55°) <sup>2</sup>		4.9 and 3.1
SCOP (0°/35° and 0°/55°, EN 14825)		5.6 and 4.2
Charge circuit flow (0/35, 30–110 hz, delta T 5, water)	l/s	1.1 – 4.1
Charge rated flow <sup>2</sup>	l/s	1.86
Brine flow (0/35, 30–110 hz, delta T 3, ethanol-water 28%)	l/s	1.6 – 5.5
Brine rated flow <sup>2</sup>	l/s	2.43
Maximum allowed external pressure loss, with charge rated flow	kPa	145
Maximum allowed external pressure loss, with brine rated flow	kPa	152
Minimum ventilation rate for safety mode (Qmin)	m <sup>3</sup> /h	113
Ventilation rate in normal mode	m <sup>3</sup> /h	34
Minimum volume of the installation space	m <sup>3</sup>	4.7
Recommended/maximum temperature of the installation space	°C	+15... +25/+30
Heating system / brine circuit maximum operating pressure (consider network pressure)	bar	10/10
Heating water maximum output temperature	°C	+75
Operational temperature, collector	°C	-10... +30
Compressor quantity, type	pc	1, Scroll (frequency controlled)
Integrated circulation pumps		yes (frequency converter)
Electrical connection		400 VAC, 3L+N+PE, 50 Hz
Operating current of the protective device	A	3 x 80
Hermetically sealed		yes
Refrigerant		R290
GWP (global warming potential)		0.02
Refrigerant charge	kg	3.3
CO <sub>2</sub> equivalence - tonnes CO <sub>2</sub> e	ton CO <sub>2</sub> e	0.000066
Sound level <sup>3</sup>	dB(A)	43 / 46
Sound level <sup>4</sup>	dB(A)	43 – 52
Connections		
Heating network		G2" it
Collector		G1 1/2" it
Ventilation	mm	125
External dimensions (depth x width x height)	mm	790 x 1060 x 1750
Weight	kg	650

<sup>1</sup> Power values in accordance with EN 14511 <sup>2</sup> B0/W35 in accordance with EN 14511, at a compressor speed of 3000 rpm <sup>3</sup> Measured in accordance with EN 12102 and EN 3741 under conditions 0/35 and 0/55 at a compressor speed of 3000 rpm <sup>4</sup> Measured in accordance with EN 12102 and EN 3741 under conditions 0/35 at the compressor's minimum and maximum speeds

# Gebwell Taurus EVIC heat pump

- IoT heat pump for heating large properties

## Gebwell Taurus EVIC is a tandem heat pump with two EVI compressors and an IoT controller for heating large properties.

Thanks to the EVI compressors, the output power of the heat pump is high even at high condensation temperatures. The compressor economizer recovers excess heat from the fluid line, which is then used to vaporise the refrigerant into the compressor's low pressure block. Taking advantage of the high evaporation temperature of the high temperature provides better efficiency. Economizer's performance improves at higher condensing temperatures.

The IoT controller allows the system's field data to be stored in a cloud service and used in system development.

The data being stored in the cloud service enables adjustment based on weather forecasts and learning the thermal capacity and the heating/cooling behaviour of a certain property. Future IoT services include proactive maintenance and adjustment based on weather forecasts.

Thanks to the cloud service, the controller software can be updated remotely and the system can be monitored and controlled online, using a browser-based Gebwell Smart Hub. Possible external interfaces to other property management systems are also possible.

Taurus EVIC heat pump comes in two capacities Taurus 80 EVIC and Taurus 110 EVIC. Taurus EVIC heat pump is also equipped with a de-superheater exchanger.

- Manufactured in Finland
- Easy to maintain and reliable
- Tandem with two EVI compressors
- Electronic expansion valve
- Brazed plate heat exchangers
- Top efficiency with partial loads
- Controller with IoT features
- Learning and evolving system
- Monitoring and control also remotely from Gebwell Smart Hub



		Taurus 80 EVIC	Taurus 110 EVIC
GTIN		6430079400564	6430079400571
Power values (according to EN 14511)			
Heating output	kW	71.4 and 74.3	93.6 and 97.8
Cooling output (0°/35° and 0°/55°)	kW	56.4 and 50.0	74.1 and 65.2
Electrical power (0°/35° 0°/55°)	kW	16.1 and 25.5	20.9 and 32.6
Rated heating output (0°/35° 0°/55°)	kW	71.4 and 74.3	93.6 and 97.8
Rated electrical power (0°/35° and 0°/55°)	kW	16.1 and 25.5	20.9 and 32.6
COP (0°/35° and 0°/55°)		4.4 and 2.9	4.5 and 3.0
SCOP (0°/35° and 0°/55°. according to EN14825)		5.2 and 4.4	5.2 and 4.5
Heating circuit rated flow	l/s	2.4	3.2
Brine		Denaturated ethanol 25-30 wt-%	Denaturated ethanol 25-30 wt-%
Brine rated flow	l/s	4.5	5.9
Maximum allowed external pressure loss at the brine rated flow	kPa	130	120
Heating system / brine circuit maximum operating pressure (consider network pressure)	bar	6 / 6	6 / 6
Heating water maximum output temperature	°C	0/+65 from condenser	0/+65 from condenser
Operational temperature. collector	°C	-5...+20	-5...+20
Compressor		Scroll (EVI)	Scroll (EVI)
Number of compressors		2	2
Built-in heating pump		yes (frequency controlled)	yes (frequency controlled)
Built-in source pump		yes (frequency controlled)	yes (frequency controlled)
Electrical connection		400 VAC, 3L+N+PE, 50 Hz	400 VAC, 3L+N+PE, 50 Hz
Operating current of the protective device	A	3 x 80	3 x 80
Contains fluorinated greenhouse gases		yes	yes
Hermetically sealed		yes	yes
Refrigerant		R410A	R410A
GWP (Global Warming Potential)		2088	2088
Refrigerant charge	kg	10.4	10.4
CO2 equivalence - tonnes CO <sub>2</sub> e	ton CO <sub>2</sub> e	21.715	21.715
Sound power level	dBA	52-58	52-58
Dimensions and connections			
Outer dimensions (length x width x height)	mm	1150 x 760 x 1550	1150 x 760 x 1550
Weight	kg	680	680
Heating network		G2" it	G2" it
Collector		G2 ½" it	G2 ½" it
De-superheater		G1" it	G1" it

# Gebwell Taurus Inverter Pro heat pump

## - IoT inverter heat pump for heating large properties

**Gebwell Taurus Inverter is an inverter-controlled heat pump for heating large properties. Taurus Inverter Pro heat pump has a controller that enables IoT features.**

IoT features have been based on using the installed system data stored in the cloud service and on a smart and learning controller.

IoT features include adjustments based on weather forecasts and learning the thermal capacity and the heating/cooling behaviour of a certain property. In the future, IoT will enable proactive maintenance and adjustments according to weather forecasts, for example.

Thanks to IoT, the controller software can be updated remotely and the system can be monitored and controlled online, using a browser-based Gebwell Smart Hub. Possible external interfaces to other property management systems are also possible.

Taurus Inverter heat pump has a power class of 40–100 kW with continuous adjustment and modulation by 1%. The electronic expansion valve of the heat pump adapts to power changes of the

inverter compressor, optimising the efficiency of the heat pump.

Taurus Inverter heat pump has a piston compressor, which is typically serviced instead of replacement. The costs compared to replacement are significantly lower.

- Manufactured in Finland
- Easy to maintain and reliable
- Brazed plate heat exchangers
- Serviceable piston compressor
- Electronic expansion valve
- Top efficiency with partial loads
- Controller with IoT features
- Learning and evolving system
- Monitoring and control also remotely from Gebwell Smart Hub



Taurus Inverter Pro		
GTIN		6415853626460
Power values		
Heating output	kW	40.1-94.9 and 30.6-82.3
Cooling output (0°/35° and 0°/55°)	kW	31.5-71.4 and 20.6-55.1
Electrical power (0°/35° 0°/55°)	kW	8.9-24.7 and 11.6-28.5
Rated heating output (0°/35° 0°/55°)	kW	65.3 and 52.3
Rated electrical power (0°/35° and 0°/55°)	kW	15.4 and 19.2
COP (0°/35° and 0°/55°)		4.2 and 2.7
SCOP (0°/35° and 0°/55° according to EN14825)		5.1 and 4.3
Heating circuit rated flow		2.2
Brine		Denaturated ethanol 25-30 wt-%
Brine flow	l/s	1.7 - 5.6
Maximum allowed external pressure loss at the brine rated flow	kPa	140 (2.9 l/s)
Heating system / brine circuit maximum operating pressure (consider network pressure)	bar	6 / 6
Heating water maximum output temperature	°C	0 / ~75-80
Operational temperature. collector	°C	-5...+25
Compressor		Piston
Number of compressors		1
Frequency converter		yes
Built-in heating pump		yes
Built-in source pump		yes
Electrical connection		400 VAC, 3L+N+PE, 50 Hz
Operating current of the protective device	A	3 x 80
Contains fluorinated greenhouse gases		yes
Hermetically sealed		yes
Refrigerant		R513A
GWP (Global Warming Potential)		631
Refrigerant charge	kg	23
CO2 equivalence - tonnes CO <sub>2</sub> e	ton CO <sub>2</sub> e	14.51
Sound power level	dBA	50-54
Dimensions		
Outer dimensions (length x width x height)	mm	1300 x 700 x 1860
Weight	kg	876
Connections		
Heating network		G2" et
Collector		G2" et
Venting discharge		Cu ½"

# Gebwell G-Eco® Pro heat pump

- inverter-controlled heat pump with a natural refrigerant for buildings

**Gebwell G-Eco Pro is an inverter-controlled heat pump for buildings that uses the eco-friendly and natural R290 refrigerant. R290 refrigerant has a GWP of only 0.02 and an ODP of 0.**

The inverter-controlled G-Eco Pro is capable of adjusting to the building's energy needs year-round. The compressor's continuously variable inverter control ensures the unit's output matches the network's requirements exactly without over or underheating, minimising your heating bills.

When connected to the manufacturer's Gebwell Smart cloud service, the G-Eco Pro heat pump can be controlled remotely through the browser-based Hub. Your maintenance company can view the status of the heating system and adjust heating settings remotely through the Hub.

The heat pump's controller can be easily updated remotely. Data stored in the cloud service helps the manufacturer implement continuous improvements.

The heat pump's electronic expansion valve is inverter controlled, allowing the heat pump to operate at optimal efficiency.

The G-Eco Pro heat pump is designed specifically for R290 refrigerant, and its compressor unit is completely isolated. The G-Eco Pro HT model is ideally suited for domestic hot water production thanks to its higher supply water temperature, and – with its wider operating range of the collector – also for heat recovery solutions.

- Manufactured in Finland
- Continuously adjustable heating output
- Electronic expansion valve
- Controller with IoT features
- Learning and evolving system
- Monitoring and control also possible remotely through the Gebwell Smart Hub



		G-Eco Pro 120	G-Eco Pro 120 HT
GTIN		6430079400816	6430079400823
Power values (EN 14511)			
Heating output (0°/35° and 0°/55°)	kW	52.8 – 119.0 and 50.7 - 108.0	56.5 – 129.4 and 48.0 – 119.1 <sup>1</sup>
Cooling output (0°/35° and 0°/55°)	kW	38.0 – 88.0 and 31.5 – 71.0	44.6 – 96.1 and 34.4 – 80.9 <sup>1</sup>
Electrical power (0°/35° and 0°/55°)	kW	13.8 – 29.9 and 17.5 – 39.5	11.7 – 31.0 and 15.2 – 38.8 <sup>1</sup>
Maximum electrical power	kW	40.1	54.5
Maximum operating current	A	71.5	97.1
COP (0°/35° and 0°/55°, 50 hz, EN 14511)		4.3 and 3.2	4.4 and 3.2
SCOP (0°/35° and 0°/55°, EN 14825)		4.7 and 3.9	4.9 and 3.9
Charge circuit flow (0/35, 30–70 hz, delta T 5, water)	l/s	2.5 – 5.8	2.6 – 6.1
Brine flow (0/35, 30–70 hz, delta T 3, ethanol-water 28%)	l/s	3.1 – 7.2	3.1 – 7.1
Brine		Denatured ethanol 25–30 wt-%	
Maximum allowed external pressure loss, with brine rated flow	kPa	200 <sup>2</sup> (7.3 l/s)	190 <sup>2</sup> (7.0l/s)
Heating system / brine circuit maximum operating pressure (consider network pressure)	bar	10/10	10 / 10
Heating water maximum output temperature	°C	+63	+75
Operational temperature, collector	°C	-10... +20 (+30) <sup>3</sup>	-10... +30
Compressor		Piston (frequency controlled)	
Frequency converter, regulation value	hz	30–70	30–70
Built-in heating pump		no	no
Built-in source pump		no	no
Electrical connection		400 VAC, 3L+N+PE, 50 Hz	
Sealed system		yes	yes
Refrigerant		R290	R290
GWP (global warming potential)		0.02	0.02
Refrigerant charge	kg	4.7	4.9
CO2 equivalence - tonnes CO <sub>2</sub> e	ton CO <sub>2</sub> e	0.000094	0.000098
Sound level (measured according to EN 12102 and EN 3741, 0/35, at the compressor's minimum and maximum speeds)	dB(A)	54 – 59	54 – 59
Operating current of the protective device	A	3 x 80	3 x 100
Connections			
Heating network	mm	G2 1/2" it	G2 1/2" it
Collector	mm	G2 1/2" it	G2 1/2" it
Ventilation	mm	125	125
Venting discharge	mm	Cu 35	Cu 35
External dimensions (depth x width x height)	mm	1250 x 750 x 1870	
Weight	kg	800	800

<sup>1</sup> Measured ΔT 2 in the brine circuit. <sup>2</sup> With source pump supplied by Gebwell Ltd. <sup>3</sup> temporary exceedance allowed

# Gebwell heat pump accessories

## Installation set for ground source heat pump

The installation set was designed to facilitate and speed up the installation of Aries ground source heat pump.

### Installation set includes

- Collector valve group
- Expansion tank of 12l for collector
- Safety valve for collector 2,5 bar
- Filling group for heating circuit
- Expansion tank of 12l for heating circuit
- Safety valve for heating circuit 2,5 bar
- Shut-off valve for heating circuit
- Filter for heating circuit
- Pressure meters for collector and heating circuit
- Mixing valve for DHW
- Safety valve for DHW 10 bar
- Hanging hooks

- Manufactured in Finland
- Reduces installation time considerably
- A large part of the installation accessory ready
- Collector pipes ready insulated
- Ground circuit pre-pressurized
- Speeds up the deaerating
- Collector filling valve from DHW
- Smart and neat finishing for installation
- Installable onto the side of ground source heat pump or onto the wall beside the pump



Installation set

## Cooling supplies for installation set

Supplies for completing the installation set suitable for cooling:

Delivery contents:

- Cooling pump
- Shut-off valves in/out
- Non-return valve
- Control centre for cooling



Cooling accessories for installation set

## Heating pump extension for installation set

Supplies for completing the installation with an additional pump for heating circuit, especially for radiator heating systems.

Delivery contents:

- Circulation pump
- Non-return valve
- Connectors



Heating pump extension for installation set

Product	GTIN	Feasibility, GSHP	Weight, kg	Outer dimensions (d x b x h), mm
Installation set	6415853626156	Aries	22,0	340 x 540 x 870
Cooling supplies for installation set	6415853626163	Aries	5,8	-
Heating pump extension for installation set	6415853626170	Aries	3,6	-

## Gebwell Cool cooling convector

Wall-mounted cooling convector is elegant by style and silent by operation.

Filters on the convector are washable and reusable and the convector is equipped with wireless remote control. The convector is suitable especially for domestic and office use.



- Elegant and silent
- Washable and reusable filters
- Equipped with wireless remote control
- On/Off timer
- For domestic and office use

Gebwell Cool		
Cooling		
Total cooling capacity	kW	2,49
Sensible cooling capacity	kW	1,81
Water flow	l/h	427
Pressure drops	kPa	28
Heating		
Heating capacity	kW	3,21
Water flow	l/h	427
Pressure drops	kPa	23
Air flow (max / med / min)	m <sup>3</sup> /h	500 / 370 / 290
Power supply	V / Ph / Hz	230V / 1Ph / 50 Hz
Pipe connections	G	½"
Sound pressure level (max / med / min)	dB(A)	37 / 30 / 26
<b>Dimensions</b>		
Height	mm	300
Width	mm	875
Depth	mm	220
Weight	kg	16

## Collector valve group

Valve group makes the filling and the venting of collector easy. In addition, the dirt filter removes the possible dirt particles in the liquid circulation.

DN25 and DN32 collector valve group models include an expansion vessel through which the annual liquid checks can be done.

Valve group is insulated with a polystyrene box to prevent the formation of condensation water.

Valve group is meant as accessory for all Gebwell heat pumps.



Collector valve group DN25



Collector valve group DN65-80

Collector valve group	GTIN	Feasibility, GSHP	Feasibility, kW	Expansion tank type, vol. l	Connections, GSHP	Connections, collector
DN25	6415853619813	Aries	6-13	open, 5 l	1" male	Pipe conn . 1"
DN32	6415853619752	T3 Inverter	16-30	open, 5 l	1¼" female	PEM 40
DN50	6415853619783	T3 Inverter, G-Eco Core, Gemini	30-50	-	Flange 50	Flange DN50
DN65	6415853619790	Inverter, Taurus EVIC, Taurus	85	-	Flange 65	Flange DN65
DN80	6415853619806	Inverter Pro and G-Eco Pro	100	-	Flange 80	Flange DN80

## Change-over valve set

The change-over valve set turns the water flow to heating domestic water or the water circulating in the heating system.

The change-over valve set includes the change-over valve and an actuator. Accessory for the Gebwell T3 Inverter, G-Eco Core, Gemini Inverter, Taurus EVIC, Taurus Inverter Pro and G-Eco Pro heat pumps.



Change-over valve set

Change-over valve set	GTIN	Feasibility, heat pump	Flow range l/s	Change-over valve KVS value
VV4 Change-over valve set 26-32 kW	6415853623599	T3 Inverter, G-Eco Core and Gemini Inverter	0,7-2,2	25
VV5 Change-over valve set 33-85 kW	6415853623605	Gemini Inverter, Taurus EVIC, Taurus Inverter Pro and G-Eco Pro	1,7-7	73

## Circulation pump sets for domestic water

Circulation pump set for domestic hot water circulation

The circulation pump set contains the water circulation pump, pump valve and line adjustment valve.



Hot water circulation GSHP DN20

Circulation pump set for domestic water	GTIN	Circulation pump
Hot water circulation GSHP DN15	6415853623148	Grundfos UPM3 15-50 DHW CIL
Hot water circulation GSHP DN20	64158 53623155	Grundfos UPS 25-60N
Hot water circulation GSHP DN25	64158 53623162	Grundfos UPS 25-60N
Hot water circulation GSHP DN32	64158 53623179	Grundfos UPS 25-80N
Hot water circulation GSHP DN40	64158 53623186	Grundfos UPS 25-80N

## DHW shunt

DHW shunt transfers heat from accumulator tank to heat domestic hot water.

DHW shunt includes a three-way valve and actuator as well as connectors, nuts and a sensor. DHW shunt and HEX includes heat exchanger, circulation pump, connectors and a sensor.



DHW shunt 4-8 apartments

DHW shunt	GTIN 64158..	Circulation pump	Control valve KVS value	Maximum flow l/s
DHW shunt 1 apartment	53626569	-	2,5	0,27
DHW shunt 2-3 apartments	53626583	-	4	0,43
DHW shunt 4-8 apartments	53626606	-	6,3	0,68
DHW shunt 9-20 apartments	53626620	-	10	1,08
DHW shunt 21-54 apartments	53626590	-	16	1,72
DHW shunt 55-129 apartments	53626613	-	25	2,69
DHW shunt 130-175 apartments	53626576	-	40	4,30
DHW shunt and HEX 1-4 apartments	53626187	Grundfos UPM Geo 25-85	-	0,55
DHW shunt and HEX 5-16 apartments	53626194	Grundfos Magna3 25-100	-	0,99
DHW shunt and HEX 17-32 apartments	53626200	Grundfos Magna3 40-120	-	1,35
DHW shunt and HEX 33-50 apartments	53626217	Grundfos Magna3 40-120	-	1,65
DHW shunt and HEX 51-100 apartments	53626224	Grundfos Magna3 40-120	-	2,27
DHW shunt and HEX 101-150 apartments	53626231	Grundfos Magna3 40-150	-	2,96

## Heating control group

With heating control group the adjusting of heating network is easy

Connecting the heating control group to the heating network is easy and effortless. By connecting another control group to heat pump, you can heat damp spaces all-year round regardless of other spaces' heating needs.

Heating control group is meant as accessory for all Gebwell heat pumps.

### Control group includes

- Heating pump
- Shut-off valve
- Control valve with actuator
- Dirt filter
- Needed sensors, electric cables, hangers
- Wall mounting rails

- Reduces installation time
- Effortless connecting of the control group to the heating network
- Easy adjustment of the heating circuit by the heating control group

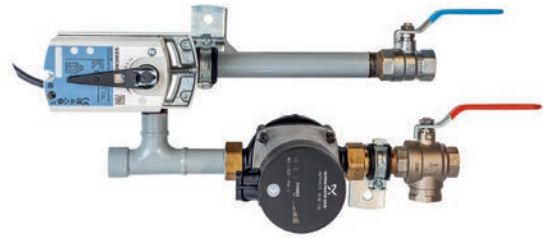

Heating control group Aries and LSR Si KV4



Heating control group LSR Si KV6.3-16



Heating control group LSR Si KV25

Heating control group	GTIN	Feasibility, heat pump	Feasibility, radiator heating, kW	Feasibility, floor heating, kW	Valve KVS value	Circulation pump
Heating control group Aries	6415853626637	Aries	1.5-7.5	1.5-7.5	4	Grundfos UPM3 Auto 15-70
Heating control group KV4 R1-23 F1-6	6415853626644	T3 Inverter, G-Eco Core, Gemini Inverter, Taurus EVIC, Taurus Inverter Pro and G-Eco Pro	1-23	1-6	4	Grundfos UPM3 Auto 15-70
Heating control group KV6,3 R23-45 F6-14	6415853626651		23-45	6-14	6.3	Grundfos Magna 3 25-100
Heating control group KV10 R45-70 F14-22	6415853626668		45-70	14-22	10	Grundfos Magna 3 25-100
Heating control group KV16 R70-110 F22-36	6415853626675		70-110	22-36	16	Grundfos Magna 3 25-100
Heating control group KV25 R110-180 F36-56	6415853626682		110-180	36-56	25	Grundfos Magna 3 40-120
Heating control group KV40 R180-240 F56-90	6415853626699		180-240	56-90	40	Grundfos Magna 3 40-120
Pump heating group 0,6 l/s - 3m	6415853619882		15-23	1-6	-	Grundfos UPM3 Auto 15-70
Pump heating group 1,7 /s - 5,5m	6415853619899		23-110	6-36	-	Grundfos Magna 3 25-100
Pump heating group 3,3 l/s - 6m	6415853619905		110-240	36-90	-	Grundfos Magna 3 40-120

Its recommended to install the block thermostat in underfloor heating. The block thermostat are delivered by Gebwell Ltd.



Pump heating group 2m3/h

Pump heating group 6m3/h

Pump heating group 12m3/h

## Automation accessories – Gebwell Smart heat pumps



Code	Name	Description
<b>Expansion modules</b>		
G5212254	TC1.2 expansion module for Gebwell Smart heat pump	Used with heating circuit mixing groups and flow sensors. Includes Climatix POL955 extension module and connectors. Does NOT include the valves, actuators or sensors.
G2931891	TC1.4 expansion module for Gebwell Smart heat pump	Used with cascade systems, to control additional / back-up heat. Includes Climatix POL955 extension module, connectors and two NTC10k water sensors with 4m leads.
G1716587	TC1.5 expansion module for Gebwell Smart heat pump	Used with active cooling feature. Includes Climatix POL955 extension module, connectors and activation of the feature on the controller. Does not include cooling tank, valves, actuators or sensors.
G1750700	TC1.6 expansion module for Gebwell Smart heat pump	Used with cooling circuit mixing groups. Includes Climatix POL955 extension module and connectors. Does not include valves, actuators or sensors.
G5790493	TC1.7 expansion module for Gebwell Smart heat pump	Used with DHW mixing group and heating/source circuits pressure sensors. Includes Climatix POL955 extension module and connectors. Does not include valves, actuators or sensors.
G3206076	TC1.8 expansion module for Gebwell Smart heat pump	Used with Auxiliary measurement module. Includes Climatix POL955 extension module, connectors and activation of the feature on the controller. Does not include valves, actuators or sensors.
<b>Communication modules</b>		
G4722856	M-bus communication module	Includes POL907 module and connectors.
G7042677	Modbus RTU communication module	Modbus allows transferring data through the Modbus protocol from the controller of heat pump to the higher-level automation system Includes POL902 module and connectors.
<b>Enclosures for expansion modules</b>		
G1699982	Enclosure for two POL955 extension modules.	Includes plastic enclosure, main switch, 24AC 40VA transformer and 24DC power supply. Does not include extension modules.
G6142649	Enclosure for three POL955 extension modules.	Includes plastic enclosure, main switch, 24AC 60VA transformer and 24DC power supply. Does not include extension modules.
<b>Flow meters</b>		
ENEM7000	Energy meter CLI - Aries, Taurus EVIC (de-superheater)	For measuring the energy produced. Includes connectors, seals and the sensor cable and its connectors. Feasability: 0,2-50 l/min (0,83 l/s) Maksimi: dt 5K = 17kW, dt 6K = 21kW, dt 7K = 24kW
ENEM8000	Energy meter CLI - T3 Inverter, Gemini Inverter	For measuring the energy produced. Includes connectors, seals and the sensor cable and its connectors. Feasability: 0,2-100 l/min (1,67 l/s) Maksimi: dt 5K = 35kW, dt 6K = 42kW, dt 7K = 49kW
ENEM9000	Energy meter - G-Eco Core, Taurus EVIC and Taurus Inverter Pro	For measuring the energy produced. Includes connectors, seals and the sensor cable and its connectors. Feasability: 5-300 l/min ( 5,00 l/s) Maksimi: dt 5K = 105kW, dt 6K = 126kW, dt 7K = 147kW



# Gebwell G-Energy® accumulator tanks

– for heating optimisation

In water-circulating heating systems, the heat generated by the heating device is stored in energy accumulators to be used for the heating of the building and domestic water. The Gebwell G-Energy energy accumulator is a Finnish product, manufactured by experts of the heating sector at the Leppävirta factory.

Our generous product range offers models to be used with different heating methods. The G-Energy energy accumulator enables the parallel use of different heating systems. Our accumulators can be connected to underfloor or radiator heating systems. G-Energy accumulators are available for both single-family houses and large properties. Our range of models includes accumulators with 501L, 1000L, 2000L, 3000L, 4000L and 5000L capacities. Some of our accumulator models, the G-Energy Coil hot water heater and some of our buffer tanks are available in 750-litre capacity.

## Easy to handle and install

Thanks to the steelframe on the bottom of the accumulator, the Gebwell accumulator is easy to transport, haul and install, regardless of model or size. The accumulators have detachable insulation, which makes it easy to carry them to confined spaces without needing to remove doorframes. Depending on the size of the accumulator, the detachable insulation comes in 3- 5 loose segments. For example, the 1000L accumulator has a diameter of 850mm without insulation. The insulation segments are attached to each other with quick latches, which makes it easy to remove or install them.

The accumulator's connections do not reside inside the insulation; to facilitate pipe installations, the connections extend to the insulation surface level. Levelling feet (adjustment tolerance 0-60 mm) allow the accumulator to be easily set to stand vertically even on an uneven surface.

## High quality and long life-cycle

The Gebwell factory in Leppävirta employs strict quality controls. Robot welding ensures first-grade welding and even quality. The tanks are made out of steel, primed, and pressure tested using water. In addition, accumulators are available in stainless or acid-resistant steel for, among other things, cooling and domestic water applications. The insulation material in the accumulators is die-cast polyurethane, which has extremely good thermal insulation capacity and minimal thermal loss.

Shape wise, Gebwell's vertical cylindrical accumulator provides the best thermal option. Ease of use has also been taken into consideration in the design of connections. The drain connection located at the front of the accumulator makes it easy to drain the accumulator.

Die-cast urethane is used for insulation in accumulators, and the surface plate of the insulation segments is a painted steel plate covered with a protective membrane.

## Sufficient fresh water

Using an energy accumulator is an ecological and economic way to produce a comfortable, even room temperature and sufficient hot water. The hot water accumulator stores and distributes the heat produced by heating systems, which is then used to heat the property and domestic hot water. In Gebwell accumulators, domestic water is heated in a copper coil, which offers a quick turnover of water. The coil distributes water in an energy-efficient manner ensuring freshness. Coils are ordered separately for accumulators with the exception of G-Energy Coil hot water heater, which comes with coils ready installed.

## Lowerable accumulators

The steel base on the base of our cylindrical 501, 750 and 1000-litre accumulators has two parts; the lower section can be removed before installation. When lowered, the height of the 501-litre accumulator is 90 mm, the 750-litre accumulator 130 mm and the 1000-litre accumulator 150 mm lower compared to the standard.

Adjustment legs (adjustment tolerance 0–60 mm) allow the accumulator to be easily set to stand vertically even on an uneven surface.

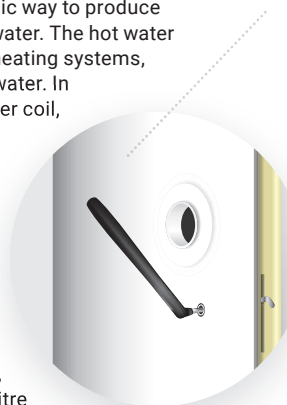

## The suitability of accumulators for different heating systems



Wood



Oil



Pellet



Solar



Geothermal heat



Cooling



Detachable insulation

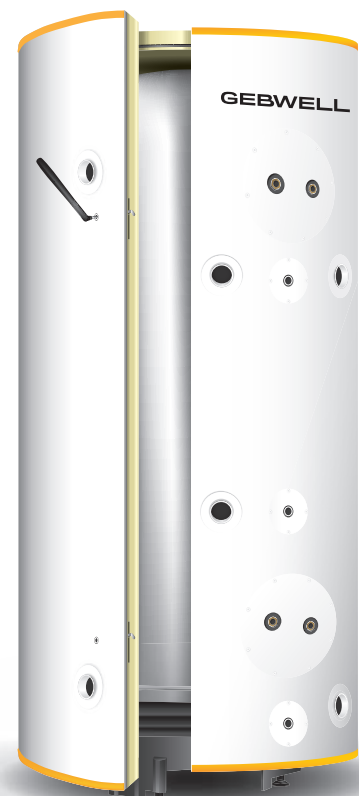

## G-Energy 300 Buffer Tank

G-Energy 300 buffer tank is a module-sized 275 L buffer tank.

Buffer tanks even out the starting intervals of heating equipment and so improve the equipment's durability, e.g., a buffer tank can reduce the number of times a heat pump's compressors need to be started.

The accumulator tank is made out of stainless steel, and the surface plate is a powder coated steel plate. The insulation used in the water heater consists of 100 mm thick die-cast CFC-free polyurethane.

The polyurethane fills the space between the surface plates and the water tank completely, which gives it an extremely good thermal insulation capacity. This means that the energy efficiency of the equipment is first-rate.

The die-cast polyurethane also acts as the accumulator's frame, making it sturdy. The levelling feet on the base make installation easy.

The SV model has two electric immersion heater connections that can accommodate a 10 kilowatt electrical immersion heater at maximum. Electric immersion heaters are ordered separately.

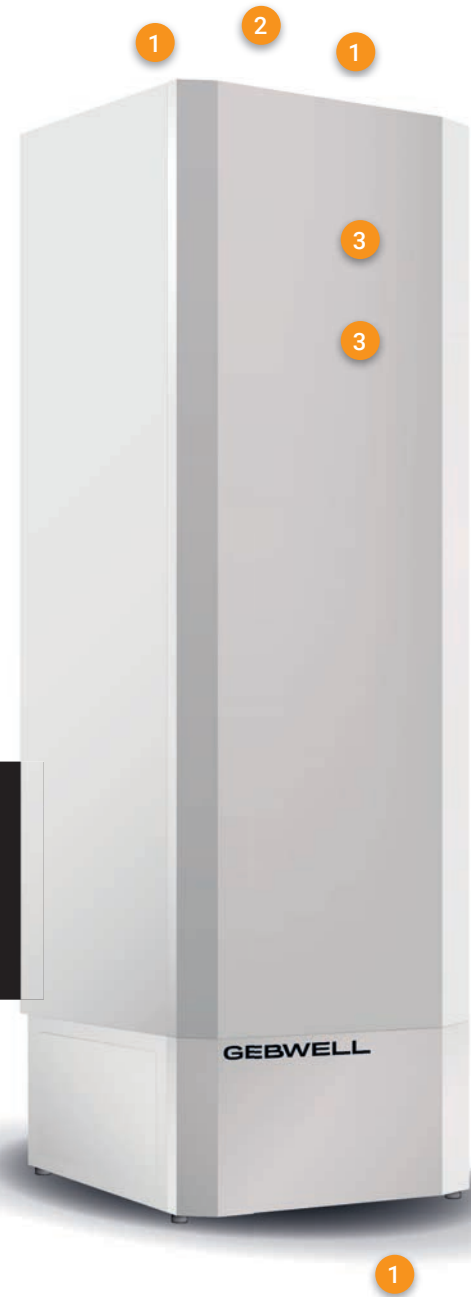

**Tank connections and connection sizes**  
 1. Charging/heating, R2"  
 2. Measurement, Ø 10mm  
 3. Electric immersion heater, R2" (300 SV)



Model		Buffer Tank 300	Buffer Tank 300 SV
GTIN		6415853623889	6415853626255
Tank capacity	L	275	275
Height	mm*	1890	1890
Width	mm	595	595
Depth	mm	595	595
Tilt measurement	mm	2000	2000
Weight	kg	90	90
Connection sizes, #1		2"	2"
Number of electric immersion heater connections	pc	0	2
Max electric immersion heater size	kW	-	10
Max temperature	°C	110	110
Max operating pressure	bar	10	10

\* + Levelling feet 0-60 mm

## Gebwell G-Energy DHW buffer tank

Gebwell G-Energy DHW is a stainless steel buffer tank for hot domestic water. The G-Energy DHW buffer tank contains hot domestic water ready for use. The G-Energy DHW is especially well suited as a part of heat pump systems for real estate that take advantage of superheating technology.

The G-Energy DHW tank is made of stainless steel (EN 1.4521), with a design pressure of 1.0 MPa (10 bar). The tank is insulated with 95 mm Neopor insulation and encased in a polypropylene cover.

The buffer tank features a vertical coil and two connections for electric heaters.

It can be used as a domestic hot water buffer tank for both detached houses and larger properties, where multiple tanks can also be connected in series if required.

The Gebwell G-Energy DHW buffer tank comes with a five-year warranty covering both materials and manufacturing.



### Accumulator connections

1. Domestic hot water
2. Coil, charge in
3. Measurement
4. Measurement/circulation/free
5. Resistor connections
6. Coil, charge out
7. Cold water
8. Drainage



G-Energy DHW		
Colour		grey
Material		1.4521
Tank capacity	L	464
Height	mm	2020
Diameter	mm	795
Tilt measurement	mm	2200
Weight	kg	93
Max temperature	°C	95
Max operating pressure	MPa	1.0
Thermal loss	W	70
Charging coil length	m	33
Max coil pressure	MPa	1.0
Energy efficiency class		<b>B</b>

## G-Energy Buffer Tank

G-Energy buffer tanks can be used to increase the water capacity of a heating system.

A higher capacity ensures a steady and sufficient flow and improves the operation and efficiency of the heat pump. A greater water capacity also extends the duty cycles and, simultaneously, the life cycle of the compressor.

G-Energy buffer tanks are available as 501L, 750L and 1000L models, with DN50 and DN65 connections and 6 bar pressure class. 1000 L buffer tank is also available with DN 80 connections.

The accumulator tank is made out of steel, primed, and pressure tested. The insulation is made out of die-cast closed-cell polyurethane, which has extremely good thermal insulation capacity and minimal thermal loss. As standard, the insulation is made out of detachable segments, which are easy to detach and reattach. The outer surface of the insulation segments is made out of painted steel plate with a protective coating.

The steel base on the base of the accumulator makes hauling easier. The base has two parts; the lower section can be removed before installation. When lowered, the height of the 501-litre accumulator is 90 mm, the 750-litre accumulator 130 mm and the 1000-litre accumulator 150 mm lower compared to the standard.

The accumulator has levelling feet with a 60 mm adjustment tolerance that makes it easy to set the accumulator to stand vertically.



### Tank connections and connection sizes

1. Charging/heating, R2" / DN65
2. Measurement, R1/2" the lowermost in front R1" (2/4)
3. Venting, R2"
4. Drainage, R1"



## G-Energy buffer tank

Model		Buffer Tank 501L DN50	Buffer Tank 501L DN65	Buffer Tank 750L DN50	Buffer Tank 750L DN65	Buffer Tank 1000L DN50	Buffer Tank 1000L DN65	Buffer Tank 1000L DN80
GTIN (64158...)		53623919	53623926	6430079400168	6430079400175	53623964	53623971	53626538
Tank capacity	L	501	501	750	750	1000	1000	1000
Height	mm <sup>1</sup>	2030	2030	2100	2100	2150	2150	2150
Height		1940	1940	1970	1970	2000	2000	2000
Diameter	mm <sup>2</sup>	600 / 780	600 / 780	750 / 930	750 / 930	850 / 1030	850 / 1030	850 / 1030
Tilt measurement	mm <sup>3</sup>	2100	2100	2100	2100	2200	2200	2200
Weight	kg	180	180	200	200	260	260	260
Connection sizes, #1		2"	DN65	2"	DN65	2"	DN65	DN80
Max temperature	°C	110	110	110	110	110	110	110
Max operating pressure	bar	6	6	6	6	6	6	6

<sup>1</sup> +Levelling feet 0-60mm

<sup>2</sup> Measurements: insulation removed/installed (insulation thickness 90mm)

<sup>3</sup> Tilt measurement with insulation detached

## G-Energy SV and PW Buffer Tank

Buffer tanks are also available in models equipped with connections for electric immersion heaters, as well as models featuring flanges for domestic hot water preheating coils in addition to the electric heaters.

The G-Energy SV tank is equipped with three connections for electric immersion heaters and can be fitted with electric heaters as required to ensure heating and domestic hot water production. Equipping the tank with electric heaters enables, for example, heating a wood-heated house with electricity while the occupants are away on holiday. Electric heaters are ordered separately.

In addition to the three electric heater connections, the G-Energy PW buffer tank features two flanges for domestic hot water preheating coils. These tanks are suitable both for domestic hot water preheating and as buffer tanks for heating systems.

In heat pump applications, domestic hot water preheating improves the energy efficiency of domestic hot water production and increases the availability of hot water. Coils and electric immersion heaters are ordered separately.

The accumulator tank is made out of steel, primed, and pressure tested. The insulation is made out of die-cast closed-cell polyurethane, which has extremely good thermal insulation capacity and minimal thermal loss. As standard, the

insulation is made out of detachable segments, which are easy to detach and reattach. The outer surface of the insulation segments is made out of painted steel plate with a protective coating.

The steel base on the base of the accumulator makes hauling easier. The base has two parts; the lower section can be removed before installation. When lowered, the height of the 501-litre accumulator is 90 mm, the 750-litre accumulator 130 mm and the 1000-litre accumulator 150 mm lower compared to the standard.

The accumulator has levelling feet with a 60 mm adjustment tolerance that makes it easy to set the accumulator to stand vertically.

### Tank connections and connection sizes

1. Charging/heating, R2"
2. Measurement, R1/2" (the lowermost on side R1" (2/4))
3. Venting, R2"
4. Drainage, R1"
5. Electric immersion heater, R2"



### G-Energy SV buffer tank and G-Energy PW buffer tank

Model		SV Buffer Tank 501 L	SV Buffer Tank 750 L	SV Buffer Tank 1000 L		PW Buffer Tank 750L	PW Buffer Tank 1000L
GTIN		6430079400731	6430079400212			6430079400052	6415853623872
Tank capacity	L	501	750	1000		750	1000
Height	mm <sup>1</sup>	2030	2100	2150		2100	2150
Height when lowered	mm <sup>1</sup>	1940	1970	2000		1970	2000
Diameter	mm <sup>2</sup>	600 / 780	750 / 930	850 / 1030		750 / 930	850 / 1030
Tilt measurement	mm <sup>3</sup>	2100	2100	2200		2100	2200
Weight	kg	180	230	260		230	280
Connection sizes, #1		2"	2"	2"		2"	2"
Max coil size						LK55, bent	LK55
Number of el. immersion heater connections	pc	3	3	3		3	3
Max electric immersion heater capacity	kW	12	12	12		12	12
Max temperature	°C	110	110	110		110	110
Max operating pressure	bar	6	6	6		6	6

<sup>1</sup> +Levelling feet 0-60mm <sup>2</sup> Measurements: insulation removed/installed (insulation thickness 90mm) <sup>3</sup> Tilt measurement with insulation detached

## G-Energy Cooling Buffer Tank

G-Energy Cooling is a buffer tank designed for cooling systems.

G-Energy Cooling can be used as a buffer tank for, e.g., water coolers and other mechanical cooling systems. Buffer tanks even out the conditions between the start-up times of cooling equipment and reduce the number of times compressors need to be started.

The G-Energy Cooling buffer tank is available as 501L, 1000L and 2000L models and in 6 bar pressure class.

G-Energy Cooling is available with either a surface-treated steel or a stainless steel tank. The accumulator tanks are pressure-tested at the factory. A buffer tank has a 19mm cellular rubber insulation.

The steel base on the base of the accumulator makes hauling easier. The base on 501 and 1000 liter tanks has two parts; the lower section can be removed before installation. When lowered, the height of the 501 L accumulator tank is 90 mm, and the 1000 L accumulator tank 150 mm lower compared to the standard.

The accumulator has levelling feet with a 60 mm adjustment tolerance that makes it easy to set the accumulator to stand vertically.

### Tank connections and connection sizes

1. Charging/cooling, DN80/100
2. Venting, R1"
3. Drainage, R1"
4. Measurement, R1/2" the lowermost in front R1" (3/4)



### G-Energy Cooling buffer tank

Model		Cooling 501	Cooling RST 501	Cooling 1000 6 BAR	Cooling RST 1000
GTIN (64158..)		52380721	79400458	52380745	79400472
Tank capacity	L	501	501	1000	1000
Height	mm*	2010	2010	2130	2130
Height when lowered	mm*	1920	1920	1980	1980
Diameter	mm	640	640	890	890
Tilt measurement	mm	2100	2100	2200	2200
Weight	kg	180	180	260	260
Connection sizes #1	DN	DN80	DN80	DN80	DN100
Material		steel	stainless steel	steel	stainless steel
Max temperature	°C	110	40	110	40
Max operating pressure	bar	6	6	6	6

\* +Levelling feet 0-60 mm

## G-Energy Coil Water Heater

Equipped with coils, G-Energy Coil is suitable for heating domestic hot water together with a heat pump.

The G-Energy Coil water heater is available in 501, 750 and 1000 liter models in 6 bar pressure class. Depending on the size, the water heater includes two to five 25-metre-long coils. The 501L model is equipped with 2-3 coils, the 750L model is equipped 3-4 coils and the 1000L model with 2-5 coils. The domestic hot water is heated in coils with maximum pressure of 10 bar.

The 501 and 1000L models come with two connections for electric immersion heaters and the 750L model with three connections. The electric immersion heaters are ordered separately.

The accumulator tank is made out of steel, primed, and pressure tested. The insulation of 501 and 1000-liter is made out of die-cast closed-cell polyurethane, which has extremely good thermal insulation capacity and minimal thermal loss. As standard, the insulation is made out of detachable segments, which are easy to detach and reattach. The outer surface of the insulation segments is made out of painted steel plate with a protective coating.

The steel base on the base of the accumulator makes hauling easier. The base has two parts; the lower section can be removed before installation. When lowered, the height of the 501-litre accumulator is 90 mm, the 750-litre accumulator 130 mm and the 1000-litre accumulator 150 mm lower compared to the standard.

The accumulator has levelling feet with a 60 mm adjustment tolerance that makes it easy to set the accumulator to stand vertically.



### Tank connections and connection sizes

1. Coil, Cu22
2. Charging, R2"
3. Venting, R1"
4. Electric immersion heater, R2"
5. Drainage, R1"
6. Measurement, R1/2" the lowermost in front R1" (5/6)



## G-Energy Coil Water Heater

Model		Coil 501 2x25	Coil 501 3x25	Coil 750 3x25	Coil 750 4x25	Coil 1000 2x25	Coil 1000 3x25	Coil 1000 4x25	Coil 1000 5x25
GTIN		641585 2380585	643007 9400540	64033079 400113	64033079 400137	64158 52380622	64158 52380639	64158 52380646	64300 79400854
Tank capacity	L	501	501	750	750	1000	1000	1000	1000
Height	mm <sup>1</sup>	2030	2030	2100	2100	2150	2150	2150	2150
Height when lowered	mm <sup>1</sup>	1940	1940	1970	1970	2000	2000	2000	2000
Diameter	mm <sup>2</sup>	600 / 780	600 / 780	750 / 930	750 / 930	850 / 1030	850 / 1030	850 / 1030	850 / 1030
Tilt measurement	mm <sup>3</sup>	2100	2100	2100	2100	2200	2200	2200	2200
Weight	kg	225	245	305	330	305	330	350	380
Connection sizes, #2		2"	2"	2"	2"	2"	2"	2"	2"
Number of coils	pc	2	3	3	4	2	3	4	5
Recommended flow in coils	l/s	0.7	1.05	1.05	1.4	0.7	1.05	1.4	1.75
Number of electric immersion heater connections	pc	2	2	3	3	2	2	2	2
Maximum electric immersion heater capacity	kW	12	12	12	12	12	12	12	12
Max temperature	°C	110	110	110	110	110	110	110	110
Max oper. pressure	bar	6	6	6	6	6	6	6	6

<sup>1</sup> +Levelling feet 0-60mm <sup>2</sup> Measurements: insulation removed/installed (insulation thickness 90mm) <sup>3</sup>Tilt measurement with insulation detached

## G-Energy Custom Accumulator

A special accumulator for installations not suitable for our standard models.

Equipped with flexible features, the special model is fully customisable. The customer can select the capacity, material, pressure class and insulation material of the accumulator. The size of connections and the number and placement of connections and sensor pockets can also be customised. The special accumulator is available either with or without a bulkhead.



G-Energy Custom is tailored to the property and is available with, for instance, the following features:

- Capacity - 501, 750, 1000, 2000, 3000, 4000 or 5000 litres
- Pressure class - 1.5-10 bars
- Connections - the number, size and location as required
- Tank material - FE, HST or RST (maximum temperature 40 °C)
- Insulation material - polyurethane, cellular rubber, polyester fibre or no insulation
- Bulkhead - the accumulator comes with or without a bulkhead

Model		Custom 501	Custom 750	Custom 1000	Custom 2000	Custom 3000	Custom 4000	Custom 5000
Tank capacity	L	501	750	1000	2000	3000	4000	5000
Height	mm <sup>1</sup>	2030	2130	2150	2250	2400	2450	2550
Diameter	mm <sup>2</sup>	600 / 780	750 / 950	850 / 1030	1200 / 1380	1400 / 1580	1600 / 1780	1800 / 1980
Tilt measurement	mm <sup>3</sup>	2100	2100	2200	2300	2450	2600	2700
Weight	kg	depends on the model						
Connection sizes		as desired						
Max coil size		LK55	LK55	LK90	LK140	LK180	LK180	LK180
Max number of vertical coils	pc	3 <sup>4</sup>	4	5	7	8	8	10
Number of heater connections	pc	as desired						
Max heater capacity	kW	12 <sup>4</sup>	12	12	12	12	12	12
Max temperature	°C	110	110	110	110	110	110	110
Max operating pressure FE <sup>5</sup>	bar	6	6	6	6	6	3	3
Max operating press. stainless steel <sup>5</sup>	bar	10	6	6	6	6	3	3

1 +Levelling feet 0-60mm 2 Measurements: insulation removed/installed (insulation thickness 90mm) 3 Tilt measurement with insulation detached using the height and diameter measurements above 4 With three vertical coils in 501 liter accumulator tank, the maximum heater capacity is 6 kW 5 Larger operating pressures are to be consulted case by case with Gebwell Ltd. sales

NOTE! The accumulators can be made lower within certain parameters

## Gebwell KVL300 hot water heater

Gebwell KVL300, modular hot water heater is designed for producing and storing domestic hot water for detached, row and vacation houses. The hot water heater produces enough hot water for the entire family. The advanced insulation solutions result in substantial additional savings and reduce environmental impact.

Gebwell thermal storage tanks have been designed, manufactured and tested in Finland. When designing the storage tanks, attention has been paid to allow easy installation and servicing. The storage tanks have been manufactured using high-quality components and operational reliability and usability are top class.

Gebwell KL300 is a vertical, free-standing unit. The installation is made easier using levelling feet on the base.

Tank of the hot water heater is made of special stainless steel. The maximum service pressure of the tank is 1.0 MPa (10 bar). Exterior is made of white powder-painted steel sheet metal. Other colour options are available upon special order.

Insulation in the hot water heater is pressure-moulded, freon-free polyurethane. The urethane fills the entire space between the exterior sheeting and the water tank, which results in excellent thermal insulation properties and top-notch energy-efficiency. Pressure-moulded polyurethane also acts as the frame of the storage tank and makes it sturdy.

The heating element in the KVL300 is an Incoloy Electric immersion heater which can be used with either 1- or 3-phase connection.

The KVL300 hot water heater is equipped with continuous heating temperature control, a maximum temperature limiter (thermostat and overheating protection) and an on-off switch.

### Installation

In the back of the hot water heater, there is room on both sides of the tank for pipe installations directing either up or to the side.

The hot water heater has a mixture valve and a set of safety valves (thermostat valve, shut-off/check valve, safety/drainage valve) for water connections. The set of safety valves include a safety valve that opens at 1.0 MPa (10 bar).

### Warranty

Gebwell hot water tanks have a two-year warranty against defects in materials and manufacturing defects.

Manufactured in Finland  
Energy saving  
Noiseless  
Continuous heating temperature control  
Easy installation

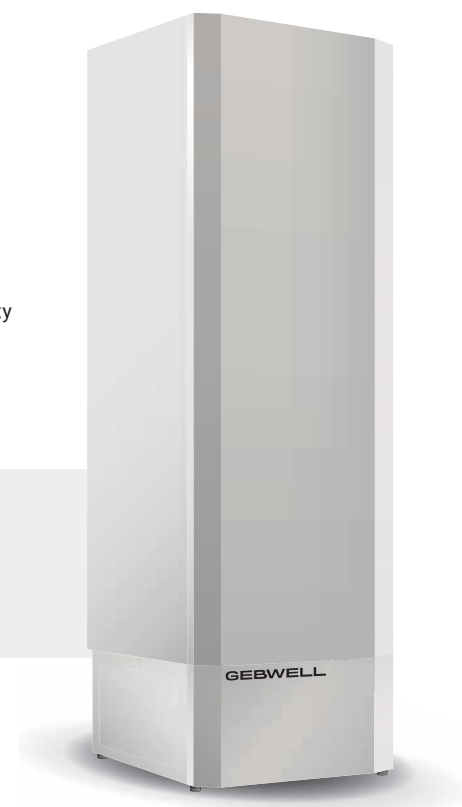

## Gebwell KVL300 hot water heater

	Gebwell KVL300	Gebwell KVL300 DN32	Gebwell KVL300 DN32, 1 SV
GTIN	6415852380523	6415852380998	6415852380929
Colour	White	White	vit
Volume	275 l	275 l	275 l
Max. allowed temperature	100 °C	100 °C	100 °C
Min. allowed temperature	0 °C	0 °C	0 °C
Max. allowed operating pressure	1,0 MPa	1,0 MPa	1,0 MPa
Power	3 kW	3 kW	3 kW
Heat loss	1,23 kWh / day	1,23 kWh / day	1,23 kWh / day
Number of electric heater connections	-	-	1
Max heater effect	-	-	10
Energy efficiency class	<b>C</b>	<b>C</b>	<b>C</b>
Voltage	50/60 Hz 230/400 V 3P~/ 1P~	50/60 Hz 230/400 V 3P~/ 1P~	50/60 Hz 230/400 V 3P~/ 1P~
Protection class*	IPX4	IPX4	IPX4
Recommended fuse size	3x6 / 1x16	3x6 / 1x16	3x6 / 1x16
Maximum fuse size	3x16 / 1x16	3x16 / 1x16	3x16 / 1x16
Dimensions (depth, width, height)	595 x 595 x 1890 mm	595 x 595 x 1890 mm	595 x 595 x 1890 mm
Weight	90 kg	90 kg	90 kg

\* The IPX4 splash proof IP rating is achieved by installing the accumulator on a solid floor next to a wall.

## Domestic hot water coil

Coil for producing domestic hot water in accumulator tanks.

Producing domestic hot water in high-speed flow copper coil is energy efficient and ensures freshness of water. Structural pressure of the coil is 10 bar and material is 22 mm finned copper.

Coils are ordered on tanks separately with the exception of G-Energy Coil water heaters, which come with coils installed.

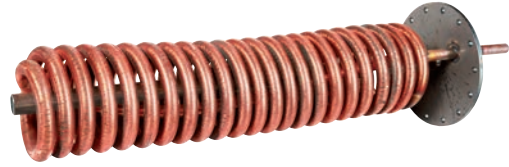

Model	GTIN number	Maximum flow l/s	Copper pipe length m	Heat transfer area m <sup>2</sup>	Connection DN/UK	Flange diameter mm	Feasibility, tank capacity L
LK45 Coil	6415853619554	0.5	12	2.8	20	200	1000-5000
LK55 Coil	6415853619561	1.0	2 x 6	2.8	32	200	1000-5000
LK55 Coil, bent	6430079400434	1.0	2 x 6	2.8	40	200	501-5000
LK90 Coil	6415853619578	1.0	2 x 12	5.7	32	200	1000-5000

## Electric immersion heater

Immersion heaters are delivered with a thermostat and a limiter.

The operation of the accumulator can be secured by equipping it with one or more electric immersion heaters, in case the heating system is switched off or malfunctions. In addition, an accumulator equipped with Electric immersion heaters can be used for heating a wood-heated house electrically during a holiday trip, for example.



12 kW electric immersion heater and limiter



2-10 kW electric immersion heater and limiter

Model	GTIN number	Capacity kW	Material	Connection	Length mm	Immersion depth mm	Cool end mm
Electric immersion heater 2 kW	6415853623070	2.0	AISI 316L	2"	254	240	95
Electric immersion heater 3 kW	6415853623087	3.0	AISI 316L	2"	269	255	95
Electric immersion heater 4.5 kW	6415853623094	4.5	AISI 316L	2"	399	385	95
Electric immersion heater 6 kW	6415853623100	6.0	AISI 316L	2"	399	385	95
Electric immersion heater 7.5 kW	6415853623117	7.5	AISI 316L	2"	455	441	95
Electric immersion heater 9 kW	6415853623124	9.0	AISI 316L	2"	455	441	95
Electric immersion heater 10 kW	6415853623131	10.0	AISI 316L	2"	455	441	95
Electric immersion heater 12 kW	6415853626132	12.0	AISI 316L	2"	530	516	95

## GW Electric Boiler EP BL

GW Electric Boiler EP BL is a reliable and energy-efficient solution for both new heating systems and as a replacement for old boilers. Manufactured by Värmebaronen, the electric boiler is ideally suited for water-based heating systems and industrial processes.

The boilers are available in 11 output classes (52–600 kW). The output is divided into 7 or 15 steps, and the control is always based on the actual heating demand, ensuring maximum energy efficiency.

As fossil fuels are increasingly replaced by alternative heating solutions, the importance of reliable backup systems grows. The GW electric boiler is a reliable option as a backup heat source.

All models are equipped with a thermostat that keeps the supply water temperature constant. In addition, the intelligent temperature control optimizes power supply and extends the service life of the contactors, further improving reliability and durability.

- Level sensor
- Automatic air vent
- Digital display
- Connection flanges from 84 kW upwards
- Manufacturer: Värmebaronen



		GW EP 52 BL	GW EP 84 BL	GW EP 98 BL	GW EP 119 BL	GW EP 140 BL
Product code		9010331	9010332	9010333	9010334	9010335
Power stages		7	7	7	7	7
Maximum power	kW	52,5	84	98	119	140
Voltage	V	400 V 3~ + control voltage 230 V ~				
Current at maximum power	A	76	121	142	172	202
Operating current of the protective device	A	80	160	160	200	250
Power / stage	kW	7,5	12	14	17	20
Design temperature	°C	110				
Operating temperature	°C	20 – 95				
Ambient temperature	°C	10 – 30				
Cable flange		Cable gland Ø34mm	FL 21 Ø60			
Cable connection	mm <sup>2</sup>	Al/Cu 16-95mm <sup>2</sup>	M12			
Test pressure		0,86 Mpa (8,6 bar)				
Water volume vessel/Operating pressure		31 l / 0,6 Mpa (6 bar)	60 l / 0,6 Mpa (6 bar)			
Pipe connection, supply/return		R 50 INT	DN 80 PN 16			
Vent valve		Yes				
Depth x width x height	mm	580x455x 1110	675x535x1225			
Weight, not filled with water	kg	80	135			
Minimum ceiling height*	mm	1770	1870			
Enclosure class		IP X1				

		GW EP 210 BL	GW EP 245 BL	GW EP 280 BL	GW EP 350 BL	GW EP 510 BL	GW EP 600 BL
Product code		9010336	9010337	9010338	9010339	9010340	9010341
Power stages		7	7	7	15	15	15
Maximum power	kW	210	245	280	350	511,5	600
Voltage	V	400 V 3~ + control voltage 230 V ~					
Current at maximum power	A	303	354	404	505	738	866
Operating current of the protective device	A	315	400	500	630	800	1000
Power / stage	kW	30	35	40	23,3	34	40
Design temperature	°C	110					
Operating temperature	°C	20 – 95					
Ambient temperature	°C	10 – 30					
Cable flange		FL 33 2x Ø60				FL 33 2 pcs 2xØ60	
Cable connection	mm <sup>2</sup>	M12				2 x M12	
Test pressure		0,86 Mpa (8,6 bar)					
Water volume vessel/Operating pressure		180 l / 0,6 Mpa (6 bar)				315 l / 0,6 Mpa (6 bar)	
Pipe connection, supply/return		DN 100 PN 16					
Vent valve		Yes					
Depth x width x height	mm	900x655x1665				1055x1055x1660	
Weight, not filled with water	kg	250				400	
Minimum ceiling height*	mm	2400					
Enclosure class		IP X1					

\* The ceiling height must not be lower than this value in order to allow replacement of the electric heating elements.



Features	
<b>Circuit breaker with shunt release</b>	No
	A separate power switch must be installed before the boiler. Only the operating voltage is cut off by the toggle switch on the panel.
<b>Level guard</b>	Yes
	Ensures that the boiler does not start if the water level is too low, no burnt-out electric cartridges. Safe and secure!
<b>Overheating protection</b>	Yes
	Overheating protection interrupts the operating voltage.
<b>Load guard</b>	Yes
	Protects the main fuse from overload. Current transformers are accessories.
<b>Alarms &amp; warnings</b>	Yes, <i>limited information</i> .
<b>Outgoing alarm (signal max. 230 V)</b>	Yes
<b>Thermography of contactors</b>	The contactors should be temperature measured once a year to detect any wear.
<b>0-10 V Control</b>	Yes
<b>Outdoor compensator</b>	Yes
	Control the boiler temperature using the outdoor temperature. Outdoor sensors are optional accessories.
<b>Cooling fan (accessory)</b>	A cooling fan can be installed in high ambient temperatures.
<b>Connection terminals on incoming cables</b>	Accessories, included in EP 52 BL
<b>Can be equipped with safety equipment (accessories)</b>	No
	A separate steam collection vessel with safety valves, pressure switches and dry boil protection should be installed in the pipe system.
<b>Water connection with counterflange <math>\geq 67</math> kW</b>	Yes
<b>Drain tap</b>	No
	Should be fitted in the pipe system.
<b>Automatic air vent</b>	Yes
<b>Pressure gauge</b>	No
	A separate pressure gauge is installed in the pipe system.
<b>Maximum pressure</b>	6 bar
<b>Expansion connection</b>	No
	Should be installed in the pipe system.

# Gebwell G-Power district heating substation

– Reliable heating for large properties

G-Power is prefabricated substation unit for safe connection of buildings to district heating. G-Power is applicable both for new build and refurbishing. It is effective solution that ensures stable and comfortable indoor temperature and sufficient hot water supply.

G-Power may have one or multiple circuits. Substation unit has a light and compact structure and neatly polished appearance. The design and realisation seek to ease the installability and usability, which are at an outstanding level in G-Power, making it the best choice there is.

G-Power substation units manifest long-term experience, uncompromising quality standards, and production efficiency. Application with high quality components of world famous brands ensures lower operating costs and durability. Strict quality control is present at all stages of production – all units are tested in factory conditions and ready for use. Due to adjustable base substation unit can be installed directly on the floor. After connection to district heating, building circuits, electricity supply, outdoor temperature sensor and connections for the necessary external controls and alarms – system is ready for operation.

## Equipment

The standard factory-made G-Power substation unit with two circuits includes:

- Insulated brazed or openable plate heat exchangers
- Electronic actuators for control of heating and domestic hot water circuits
- Circulation pumps for each circuit
- Shut-off and balancing valves
- Strainer
- Fill-up valve for heating system, feed valve for domestic cold water and valves for hot water circulation pump
- In Gebwell deliveries with automation included, pressure transmitter is included as standard
- Ready-made internal electrical connections
- Pump control centre including the main switch, motor protection switches, signal lights, alarm contacts and the controller

## Accessories

- Heat meter
- Water meter
- Thermometers
- Connection assembly set for primary circuit
- Deaerator
- Room temperature sensor
- Safety valves for heating network
- Differential pressure controller
- Expansion tank
- Sidestream filter
- Extra mixing circuit for A/C or underfloor heating, for example
- And other accessories



- Manufactured in Finland
- Light weight, compact design
- Easy hauling, installation and maintenance
- High quality components
- Plate heat exchangers, heat transfer plates made of acid resistant steel
- Electronic controllers for heat control

Technical values	
Design pressure	16 bar (25 bar)
DH inlet temperature	Tmax = 120°C (150°C)
Electrical supply	230/400 VAC
Approvals	CE label in accordance with the requirements of pressure equipment directives PED 2014/68/EU EAC (EurAsian Conformity Mark)

# Gebwell G-Power substation unit for detached houses

– Reliable heating for the small properties

G-Power is the perfect solution for connecting single-family houses to district heating network. G-Power is applicable for new build as well as refurbishing and it can be used along with both radiator and under-floor heating.

District heating substation G-Power is a simple, carefree and reliable heating system ensuring stable, pleasant and comfortable room temperature and sufficient supply of domestic hot water.

A substation with two circuits is independent system for heating supply and hot water preparation. The third additional circuit in three-circuit substations can be used to heat wet rooms all year round regardless of the heating need of the other rooms, for example.

G-Power is light and compact of structure and neatly polished of appearance. The design and realization seek to ease the installability and usability, which are at an outstanding level in G-Power, making it an excellent choice.

- Manufactured in Finland
- Light weight and compact design
- Excellent control automation
- A energy class circulation pumps
- Easy to install and maintain
- Neat appearance
- Stainless steel pipes

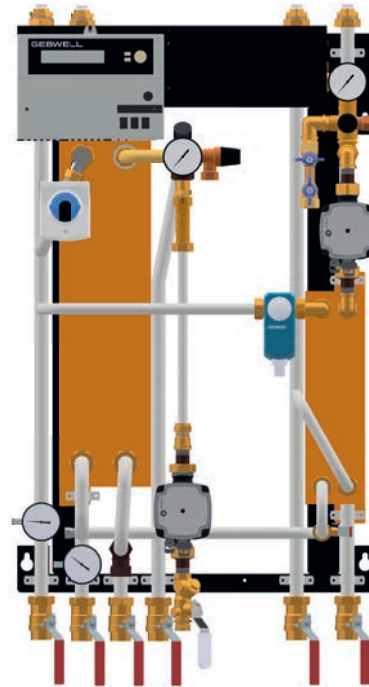

G-Power 2/100 and 2/150

## Standard equipment

- Electronic regulators for regulating the heating circuit
- Heating circulation pump
- Domestic hot water circulation pump
- Brazed plate heat exchangers for heating and domestic water
- Plug for electrical connection
- Control centre with operation switches for pumps
- Shut-off and safety valves, fill-up valve and feed valve for domestic hot water
- Pressure gauges
- Expansion tank
- Shut down thermostat for heating circulation pump
- The primary circuit equipment has been integrated into the substation

## Accessories

- Differential pressure controller if required by location conditions
- GSM-modem for remote monitoring and control (Ouman automatics)
- Pressure shock damper to compensate possible pressure shocks in domestic hot water system

## Installation

G-Power district heating substations feature excellent installability. The substations include a wall mounting kit. The substation piping is connected to district heating network and to heating and domestic water circuits.

G-Power substation can be connected to district heating network and to heating network either from bottom or top. Cold water supply, domestic hot water and hot water circulation are connected from below. The substation is connected to the electrical network with a plug, and the external sensor is connected to the control centre with a plug connection.

Gebwell G-Power®	GTIN (64158..)	DHW, kW	Radiator heating, kW		Under floor heating, kW			Dimensions, mm	Weight, kg
			Primary Secondary	70-20°C / 10-58°C	90-63°C / 60-80°C	90-43°C / 40-70°C	90-33°C / 30-39°C		
2/100H A/B	53220064/71	60	15	18	21	16	11	460 x 560 x 1000	38
2/150H A/B	53220149/56	100	15	18	21	16	11	460 x 560 x 1000	41
3/100H A/B	53220026/88	60	15	18	21	16	11	460 x 560 x 1000	51
3/150H A/B	53220170/87	100	15	18	21	16	11	460 x 560 x 1000	54
2/200	53220095	120	31	50	22	17	12	500 x 760 x 1200	55

## G-Power markings

G-Power 2/100 H A

- 2/3 number of circuits
- 100 Power class: detached houses
- 150 Power class: semi-detached houses
- 200 Power class: semi-detached and terraced house
- H Hexonic heat exchangers
- A/B Valve size:
  - A DHW: 1,6 and heating 0,4
  - B DHW: 1,0 and heating 0,25

- All the substation can be connected to radiator or underfloor heating
- The 3. circuit dimensioning on 3/100 and 3/150 are according to the maximum power of 30-39C temperature programme

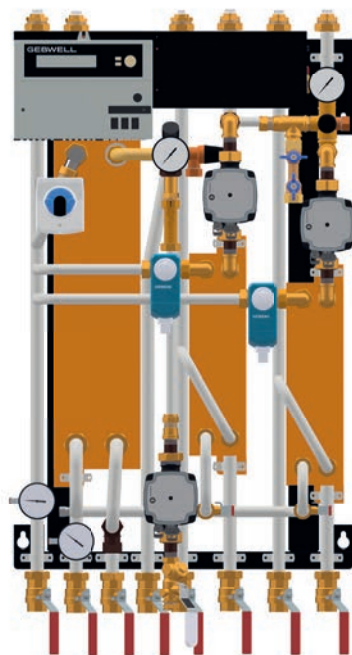

G-Power 3/100 and 3/150



G-Power 2/200

# Gebwell G-Power Smart district heating substation

– Smart heating for large properties

The Gebwell G-Power Smart district heating substation always comes with an internet connection. Using a cloud service, the system connects to the Gebwell Smart Hub, where those responsible for the heating of the property can easily monitor and adjust the system via the remote connection. Using the system via a remote connection saves time, money and effort.

G-Power Smart district heating substation allows for adding a parallel heat source, such as heat recovery from exhaust air or ground source heat.

Optional, flat-specific temperature and relative humidity measurements, remote meter readings for cold and hot water, up-to-date measurement data and APIs for property management systems, for example, are available for G-Power Smart District Heating Substation.

The G-Power Smart district heating substation is ideal for radiator, underfloor and air heating as well as for the heating of domestic water. The heating substation is designed so as to enable connecting large residential properties as well as commercial and industrial properties to district heating. It can be fitted in new constructions and renovation projects. G-Power Smart is available as 1-circuit and multiple circuits versions. The G-Power Smart District Heating Substation is designed to be installed on a floor and is delivered equipped with an adjustable stand.

The pipes of the heating substation are connected to district heating, heating, ventilation and domestic water networks. Additionally, you need to connect electricity, an external probe, and any required external control and alarm systems.

- Manufactured in Finland
- Parallel heating source ready
- Remote monitoring and control using browser-based Gebwell Smart Hub
- Allows for various extensions including flat-specific measurements, remote water meter readings, and adjustments based on local weather forecasts

## Accessories for G-Power Smart system

- Adjustments according to local weather forecast
- Accurate and precise flat-specific measurements
- Smart radiator valves
- Remote water meter readings
- APIs



# Gebwell district cooling substation

- energy efficient cooling of properties

More and more in Europe, especially in Northern countries like Finland, the cooling of properties is being centralized. The principle of district cooling system is similar to that of district heating. In district cooling, cold is produced in centralized plants, from where it is transported in form of water in pipeline network and delivered to consumer homes, where is subsequently used for cooling.

District cooling systems can serve different kind of properties, including offices, apartment buildings, hotels, sports fields, etc.

District cooling systems are much more efficient than conventional air conditioning systems, as worked out heat by cooling can be centrally disposed of and re-used. This way the system does not only save money, but also reduces greenhouse gas emissions.

In conventional air conditioning systems the unneeded heat in most cases is thrown in the air and not used. In district cooling the excess heat is gathered from the consumer to energy company's district cooling water and reused for district heating.

For the distribution of cooling in buildings special cooling substations are used, distributing the right amount of energy in the building. G-Power substation units, which are adapted for cooling, can be used for this purpose. The cooling can be distributed by using local fan coil units, central air cooling system, chilled ceilings and other systems.

- Improved energy efficiency
- Comfort and convenience for consumers
- Lack of noisy equipment in a window or on the roof
- Environment protection
- Reliability
- Reduction of costs in construction phase
- Improving building's aesthetics



- Manufactured in Finland
- High quality components
- Brazed or gasketed plate heat exchangers
- Light weight and compact design
- Easy to hauling, installation and maintenance

#### Technical values

Design pressure	16 bar (25 bar)
Electrical supply	230/400 VAC

# Gebwell G-Power® Compact district heating substation

– Compact district heating substation with a 2-stage DHW heat exchanger

G-Power Compact is a floor-mounted district heating substation for installation next to a wall, including a 2-stage heat exchanger for heating domestic water. G-Power Compact is suitable for connecting row houses and blocks of flats to a district heating network. The product can be installed in new buildings or retrofitted during renovations.

Thanks to its compact size, the G-Power Compact district heating substation is also suitable for small utility rooms. The G-Power Compact heating substation requires an installation space just 1,000 mm wide and 600 mm deep. The primary connections point downwards, and the secondary circuit connections point upwards.

The 2-stage heat exchanger for domestic hot water enables a post-cooling connection, also known as an intermediate supply connection, which uses the temperature of the district heating water returning from the heat exchanger to alleviate heat loss in the district heating water

## Post-cooling/intermediate supply connection

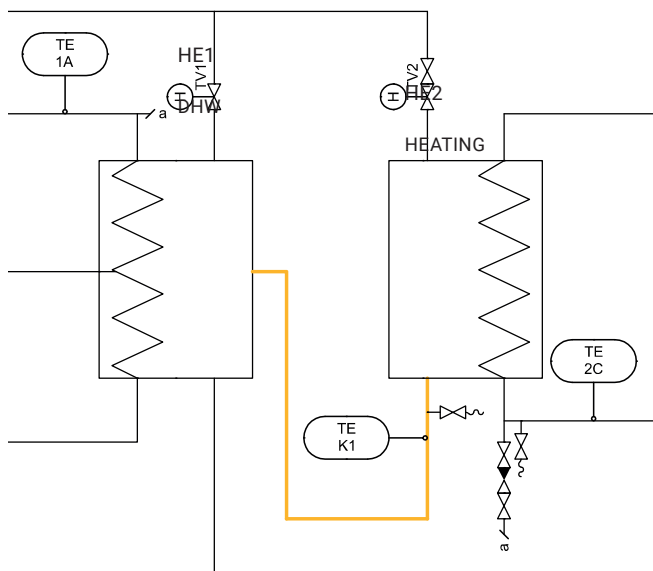

## Standard equipment

The following come as standard in the factory-ready dual-circuit G-Power Compact district heating substation:

- Brazed and insulated plate heat exchangers
- Electronic actuators to control the heating network and hot domestic water
- Heating and domestic hot water circulation pumps
- Shut-off and balancing valves
- Dirt separator
- Filling valve for the heat supply network, supply valve for cold domestic water, and valves for the hot water circulation pump
- Gebwell deliveries that include automation also come with a pressure transmitter as standard
- Internal electrical connections
- Pump control centre, including a master switch, motor protection switches, indicator lights, alert contacts, and a controller

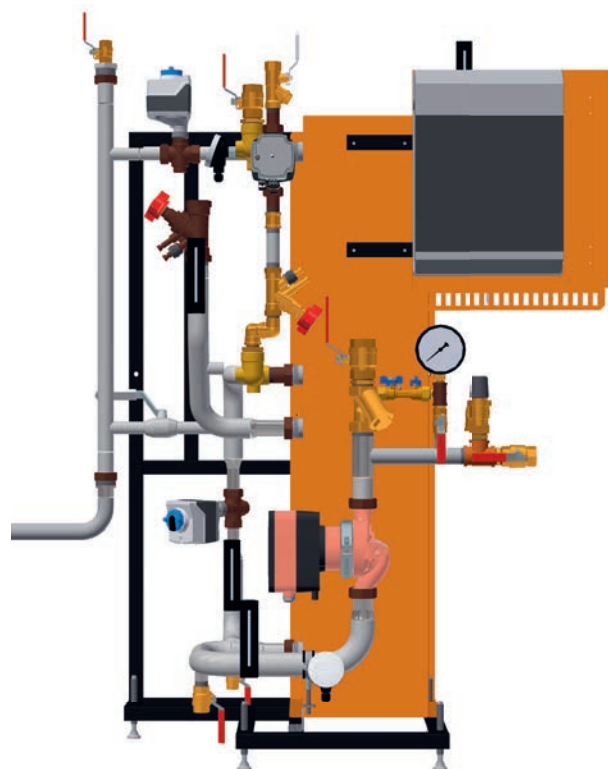

- 2-stage domestic hot water heat exchanger
- Wall-adjacent installation
- Easy to haul, install and maintain
- High-quality components
- Specially designed for small utility rooms
- Manufactured in Finland

## Technical specifications – G-Power® Compact

	Power class
Domestic hot water	120–250 kW
Underfloor heating (30–35)	12–55 kW
Radiator heating (30–60)	70–190 kW
Dimensions	
Depth	600–650 mm
Width	980–1,050 mm
Height	1,450–1,550 mm
Weight	100–150 kg
Automation options	Ouman or Siemens
Control valve options	Ouman or Siemens
Accessories	
Differential pressure controller	Supplied separately
Water meter	Supplied separately
Structural pressure	16 bar
District heating supply temperature	Tmax = 120°C
Power supply	230 VAC
Approvals	CE-marked in accordance with the Pressure Equipment Directive PED 2014/68/EU

## G-Power Compact connections and componer

### G-Power Compact connections

1. District heating supply
2. District heating return
3. Heating supply
4. Heating return
5. Domestic hot water
6. Cold water supply
7. Domestic hot water circulation

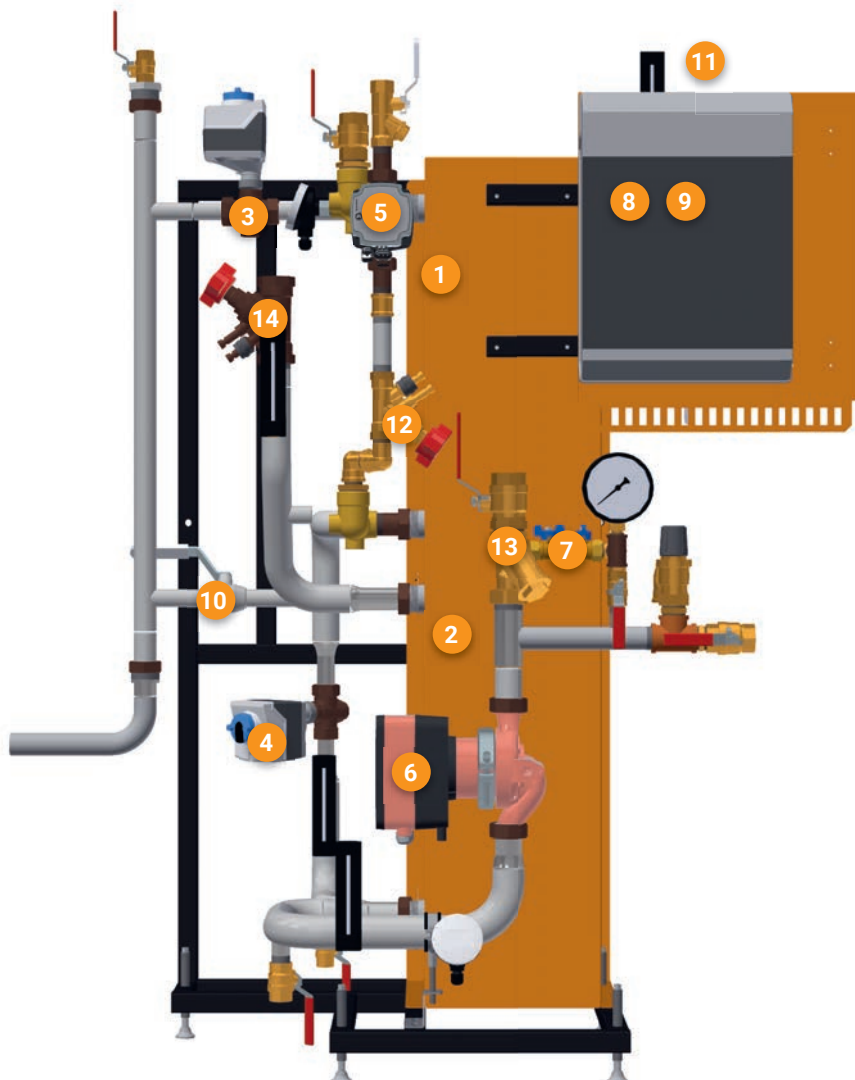
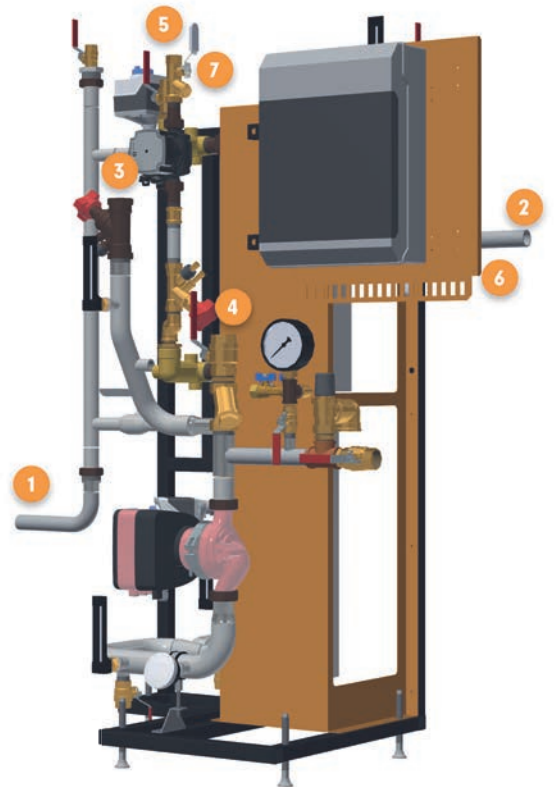

### G-Power Compact components

1. Domestic hot water heat exchanger, LS1
2. Heating heat exchanger, LSS
3. Domestic water control valve, TV1
4. Heating control valve, TV2
5. Circulator pump, domestic hot water
6. Circulator pump, heating
7. Heating circuit filling valve
8. Controller
9. Control centre
10. Summer shut-off valve for heating
11. Domestic hot water maintenance shut-off valve
12. Domestic hot water circulation balancing valve
13. Heating dirt separator
14. Heating balancing valve

## GebFilter side stream filter

Solid substances found in the fluid circulating in a heating and cooling system can cause malfunctions in the system components and thus impair the exchange of heat and shorten the life of the equipment.

The GebFilter side stream filter effectively removes solid dirt found in the fluid, making the system run more reliably and extending its life cycle.

There are two models of GebFilter side stream filters available: GebFilter 10" ja GebFilter 20".

### Structure

The side stream filter consists of a filter frame, a filter tank, and a replaceable filter cartridge. The filter frame has a vent coupling on the input/output side.

To ensure efficiency, the filter cartridge of the side stream filter should be replaced at regular intervals. We recommend replacing the cartridge once a month in the first 3–4 months after the installation of the side stream filter. After that, it is advisable to replace the filter cartridge once a year or as needed, depending on the accumulation of sediment. Filter cartridges can be ordered from Gebwell Ltd.



### Technical specifications

Material, frame	EN1.4301
Filtering rate	50 µm
Maximum flow	0,83 l/s
Maximum operating temperature	80 °
Maximum operating pressure	6 bar

## GebVent Air and Dirt Separators

Air and dirt separators remove the air/oxygen and contaminants from the fluid circulating in the heating and cooling system.

### GebVent Air - air separator

The GebVent Air air separator automatically removes air from water-circulating heating and cooling systems.

The net inside the separator collects the air and microbubbles together into a larger air bubble that rises to the top of the separator. The air bubble exits the separator via the automatic air vent valve at the top.

There is also a separate air vent at the top of the air separator that removes air from the network while filling it.

### GebVent Dirt - dirt separator

The GebVent Dirt dirt separator is used in closed heating and cooling systems.

The use of a dirt separator protects the components of the heating system from damage caused by dirt.

Unlike strainers, the dirt separator removes the dirt from the system while it's running.

### GebVent Air Dirt - air and dirt separator

GebVent AirDirt is a combined air and dirt separator, which removes both air and dirt from the system.



Technical specifications	GebVent Air - air separator	GebVent Dirt - dirt separator	GebVent Air Dirt air and dirt separator
Pipe sizes	DN50-250	DN50-250	DN50-300
Operating temperature	0-120 °C	0-120 °C	0-120 °C
Pressure class	PN10	PN16	PN10
Strainer material	EN1.4301	EN1.4301	EN1.4301
Frame material	P235GH TC1/TC2	P235GH TC1/TC2	P235GH TC1/TC2
Welding couplings	P235GH TC1/TC2	P235GH TC1/TC2	P235GH TC1/TC2
Flanges	P235TR1	P235TR1	P235TR1



# Finnish professional in environmentally friendly heating and cooling of buildings.

**GEBWELL**

PURE HEAT

Gebwell Ltd. reserve the right to changes.

Gebwell Ltd.  
Business ID FI20089567  
Patruunapolku 5, FI-79100 Leppävirta, FINLAND  
Tel. +358 20 1230 800  
info@gebwell.fi, gebwell.com

