

An efficient and environmentally friendly solution for property heating

Gebwell G-Eco® commercial heat pumps



GEBWELL
PURE HEAT



Warm regards from Finland

We are known for our environmentally-friendly heating and cooling solutions – we make pure heat in Northern Savonia.

Our base and our roots are in Leppävirta, Finland, where we have our headquarters and more than 20,000 m² of production facilities.

Towards a cleaner future

As Finns, we understand the importance of heating. It drives our desire for progress. A desire to continuously create cleaner and smarter solutions for heating and cooling homes and properties. We believe utilizing and using clean heat is an attitude, an act of goodwill for the climate. We aim to pioneer the energy sector on the road towards a cleaner future.

We're surrounded by more possibilities than ever before. The energy industry is in a turning point as people are increasingly interested in the wellbeing of the planet and the ways anyone of us can contribute to a better tomorrow.



Wide range – own collection and design

Plenty to choose from

We manufacture devices for utilising environmentally-friendly heating methods, district heating and ground source heat, as well as the exhaust air from buildings. Our product range includes district heating substations, ground source heat pumps and energy accumulators. We also manufacture and sell Pivaset fire extinguishing products.

In-house design department

We have invested in our own design department and laboratory. In-house design ensures a high standard of product quality in development and testing. We are continuously developing with the aim of ensuring that our devices are reliable and easy to install and use. The fruits of our product development include the new real estate heat pumps presented in this brochure.

One of the largest in Finland

Our devices provide reliable heating for increasing numbers of public buildings, industrial properties and housing companies. Our real-estate-class district heating substations and heat pumps are among the most popular in Finland.

We are continuously educating

We provide our customers and partners with free training on how to install and maintain our heat pumps. Our expert technical support team is also available for professionals to consult.

Ground source heat – clean and renewable energy

Ground source heat is energy that the soil has captured from the sun and geothermal energy from within the Earth – energy that can be harnessed by ground source heating pump technology to heat buildings and domestic water. This environmentally friendly local heat is available to everyone – all that is needed is the equipment to make use of it.

A ground source heating system includes devices for recovering and distributing thermal energy. A ground source heat pump is at the heart of a ground source heat system.

Ground source heat is extracted by a brine circuit, which can be embedded in the surface soil or a body of water or sunk into an energy well drilled into the rock. Ground source heat is clean, renewable energy that does not consume natural resources when it is transmitted and does not need any transportation equipment.

Ground source heat does not cause carbon dioxide or particle emissions that accelerate global warming, so it is an ecological form of heating.

Waste heat to reuse with a heat pump

In addition to conventional ground source heat, heat pumps can exploit heat that otherwise goes unused: waste heat, such as the heat in the exhaust air, industrial processes and agricultural sludge.

When a ventilation machine extracts air from inside a block of flats, it also removes a significant amount of heat energy that has already been paid for. Exhaust air heat recovery means recovering this thermal energy and reusing it to heat the building.

The exhaust air fan is replaced with a heat recovery unit where the heat exchanger collects the heat from the exhaust air and transfers it to the heat collecting liquid on the other side of the exchanger.

The heated heat collection liquid is conveyed to the heat pump in the building's technical room via a pipe installed in the building or on its exterior wall. The heat recovered from the exhaust air is utilised with a heat pump for heating domestic hot water or the water in the heat distribution network.

A heat recovery system is worth planning well. The planning service can be obtained either separately from a HVAC design office or as part of the site's general job. Gebwell supports design when it comes to rating and choosing the heat pump, the heat substation and the heat recovery units.





Support throughout the device's lifecycle

It is important to us that your project is a success and your customer is satisfied with their choice. The experts in our sales and after-sales department are at your disposal throughout the system's lifecycle.

We will support you in dimensioning and help you choose a device, and we can advise you on installation, commissioning and system monitoring. Our technical support team can help in matters related to maintenance, and our spare parts sales service makes it effortless to order spare parts.

A Gebwell Smart Partner Hub agreement will enable you to monitor the systems you install in real time and adjust the settings as necessary.



Support for dimensioning

The experts from our sales team will assist you in the dimensioning phase of your heating/cooling system project. Our experts have years of experience in dimensioning heat pump systems.



Specifying a suitable system

We will provide advice to help you find the optimum equipment configuration for your project's heating and cooling needs. Our design team will produce a PI graph for you to append to your quote. We can provide model representations of our devices so you can see how much space they require and decide on the ideal location.



Dimensioning tool

We offer a dimensioning tool to enable you to dimension the site and generate energy and savings calculations for the configuration you offer. We recommend commissioning a separate heat well design for sites with more than ten energy wells.



Technical support for your maintenance needs

Our technical support team is at your disposal if your system needs maintenance. Our technical experts have years of experience in maintenance and technical issues related to heat pump systems.



Spare parts service

Our spare parts sales service provides spare parts for heat pumps, district heating substations and accumulators. Our spare parts sales service will be happy to answer any questions you may have concerning spare parts, requests for quotes, and orders.



Gebwell Smart Hub

The browser-based Gebwell Smart Hub provides real-time monitoring of the fleet of devices you have installed in a cost-effective way without any on-site visits. The hub also allows you to adjust settings, silence alarms, monitor system trends and identify any necessary maintenance.



G-Eco Core 40	
GTIN code	6430079400762
Heating output (0°/35° and 0°/55°), kW ¹	10.5 – 39.4 and 8.7 – 38.7
Cooling output (0°/35° and 0°/55°), kW ¹	8.9 – 31.4 and 6.4 – 26.3
Input power (0°/35° and 0°/55°), kW ¹	2.2 – 10.6 and 3.2 – 13.7
Maximum input power, kW ¹	20
Maximum operating current, A	37
COP (0°/35° and 0°/55°, 50 hz, EN 14511)	4.6 and 3.1
SCOP (0°/35° and 0°/55°, EN 14825)	5.1 and 4.1
Refrigerant, kg	1.8
CO2 equivalence, tonnes CO ₂	0.000036
Sound level ²	45 – 54
External dimensions (length x width x height), mm	850 x 690 x 1850
Weight, kg	380

¹ Output details in accordance with EN 14511

² Measured according to EN 12102 and EN 3741, at 0/35 temperatures, with rotational speeds of 1800–6600 rpm

G-Eco[®] Core 40 heat pump

Gebwell G-Eco Core is a powerful IoT inverter heat pump that uses the eco-friendly R290 refrigerant. R290 has a minimal impact on global warming compared to traditional hydrofluorocarbon (HFC) refrigerants. R290 refrigerant has a GWP of only 0.02 and an ODP of 0.

Gebwell G-Eco Core is capable of adjusting to the building's energy needs year round thanks to its inverter-controlled compressor. Continuously variable inverter control ensures that the heat output matches the network's requirements exactly without over or underheating, minimising your heating bills.

G-Eco Core is connected to the manufacturer's Gebwell Smart cloud service, allowing the heat pump to be controlled remotely through the browser-based Hub.

New controller, IoT features

Temperature levels

- Maximum supply water temperature: +75 °C
- Recommended temperatures in the collector: -10...+20 °C (+30 °C)*

Refrigerant R290, filling 1.8 kg

Built-in source and charge pumps

Operating current of the protective device 3 x 40 A

* temporary exceedance allowed

NEW!

	G-Eco Pro 120	G-Eco Pro HT
GTIN code	6430079400816	6430079400823
Heating output (0°/35° and 0°/55°), kW¹	52.8 – 119.0 and 50.7 - 108.0	56.5 – 129.4 and 48.0 – 119.1 ²
Cooling output (0°/35° and 0°/55°), kW¹	38.0 – 88.0 and 31.5 – 71.0	44.6 – 96.1 and 34.4 – 80.9 ²
Input power (0°/35° and 0°/55°), kW¹	13.8 – 29.9 and 17.5 – 39.5	11.7 – 31.0 and 15.2 – 38.8 ²
Maximum input power, kW¹	40.1	54.5
Maximum operating current, A	71.5	97.1
COP (0°/35° and 0°/55°, 50 Hz, EN 14511)	4.3 and 3.2	4.4 and 3.2
SCOP (0°/35° and 0°/55°, EN 14825)	4.7 and 3.9	4.9 and 3.9
Refrigerant, kg	4.7	4.9
CO2 equivalence, tonnes CO₂	0.000094	0.000098
Sound level dB(A)³	54 – 59	54 – 59
External dimensions (length x width x height), mm	1250 x 750 x 1870	
Weight, kg	800	800

¹ Output details in accordance with EN 14511² Measurements carried out at collector circuit $\Delta T = 2$ K³ Measured according to EN 12102 and EN 3741, 0/35, 870–2030 rpm

G-Eco[®] Pro 120 heat pump

Gebwell G-Eco Pro is an inverter-controlled heat pump for buildings that uses the eco-friendly and natural R290 refrigerant. R290 refrigerant has a GWP of only 0.02 and an ODP of 0.

The inverter-controlled G-Eco Pro is capable of adjusting to the building's energy needs year-round. The compressor's continuously variable inverter control ensures the unit's output matches the network's requirements exactly without over or underheating, minimising your heating bills.

When connected to the manufacturer's Gebwell Smart cloud service, the G-Eco Pro heat pump can be controlled remotely through the browser-based Hub. Your maintenance company can view the status of the heating system and adjust heating settings remotely through the Hub.

The G-Eco Pro heat pump is designed specifically for R290, and its compressor unit is completely isolated.

New controller, IoT features

Temperature levels



- Max supply water temperature 0 / +63 °C | HT: 0/+75
- Recommended temperatures in the collector: -10...+20 °C (+30 °C)* | HT: -10 – +30°C

Refrigerant R290, filling 4.7 kg | HT: 4.9 kg

Operating current of the protective device
3 x 80 A | HT: 3x100 A

* temporary exceedance allowed

G-Eco heat pumps – Technical specifications

		G-Eco Core 40	G-Eco Pro 120	G-Eco Pro 120 HT
GTIN code		6430079400762	6430079400816	6430079400823
Heating output (0°/35° and 0°/55°)*	kW	10.5 – 39.4 and 8.7 – 38.7	52.8 – 119.0 and 50.7 – 108.0	56.5 – 129.4 and 48.0 – 119.1 ¹
Cooling output (0°/35° and 0°/55°)*	kW	8.9 – 31.4 and 6.4 – 26.3	38.0 – 88.0 and 31.5 – 71.0	44.6 – 96.1 and 34.4 – 80.9 ¹
Electrical power (0°/35° and 0°/55°)*	kW	2.2 – 10.6 and 3.2 – 13.7	13.8 – 29.9 and 17.5 – 39.5	11.7 – 31.0 and 15.2 – 38.8 ¹
COP (0°/35° and 0°/55°, 50 Hz, EN 14511)		4.6 and 3.1	4.3 and 3.2	4.4 and 3.2
SCOP (0°/35° and 0°/55°, EN 14825)		5.1 and 4.1	4.7 and 3.9	4.9 and 3.9
The system's energy efficiency class, intermediate climate, underfloor heating				
Charge circuit flow (0/35, 30-110 Hz, delta T 5, water)		0.5 – 1.9	2.5 – 5.8	2.6 – 6.1
Heat collecting liquid		Denatured ethanol 25-30% by weight		
Collector flow (0/35, 30-110 Hz, delta T 3, ethanol-water 28%)	l/s	0.7 – 2.4	3.1 – 7.2	3.1 – 7.1
Maximum permitted external pressure loss at nominal flow rate	kPa	100 (2.5 l/s)	200 ² (7.3 l/s)	190 ² (7.0 l/s)
Maximum operating pressure of the heating system / brine circuit (network pressure must be taken into account)	bar	10 / 10	10 / 10	10 / 10
Maximum output temperature of heating water	°C	+75	+63	+75
Operating temperature, collector	°C	-10...+20 (+30) ³	-10...+20 (+30) ³	-10...+30
Number of compressors		1	1	1
Type of compressor		Scroll (frequency-controlled)	Piston	Piston
Built-in charge pump		yes (frequency converter)	no	no
Built-in brine circuit pump		yes (frequency converter)	no	no
Electrical connection		400 VAC, 3L+N+PE, 50 Hz	400 VAC, 3L+N+PE, 50 Hz	400 VAC, 3L+N+PE, 50 Hz
Operating current of the protective device	A	3 x 40	3 x 80	3 x 100
Contains fluorinated greenhouse gases		no	no	no
Closed circuit		yes	yes	yes
Refrigerant		R290	R290	R290
GWP (Global Warming Potential)		0.02	0.02	0.02
Refrigerant charge	kg	1.8	4.7	4.9
CO ₂ equivalence	tonnes CO ₂	0.000036	0.000094	0.000098
Sound power level	dB (A)	45 – 54 ⁴	54 – 59 ⁵	54 – 59 ⁵
External dimensions (length x width x height)	mm	850 x 690 x 1850	1250 x 750 x 1870	1250 x 750 x 1870
Weight	kg	380	800	800
Heat supply circuit connections		G1 1/2" it	G2 1/2" it	G2 1/2" it
Brine circuit connections		G1 1/2" it	G2 1/2" it	G2 1/2" it
Ventilation	mm	80 mm	125 mm	125 mm
Venting discharge	mm	-	Cu 35 mm	Cu 35 mm

*Output details in accordance with EN 14511 ¹ Measurements carried out at collector circuit $\Delta T = 2 K$ ² With source pump supplied by Gebwell

³ Temporary exceedance allowed ⁴ Sound level, measured according to EN 12102 and EN 3741, 0/35, 1800–6600 rpm

⁵ Sound level, measured according to EN 12102 and EN 3741, 0/35, 870–2030 rpm

G-Eco Core 40 performance graphs The following presents the performance of the G-Eco Core 40 heat pump at various operating points. The graphs show information such as the heat pump's COP value outside the typical 0/35 or 0/55 points. In the power and COP graphs, the vertical axis represents the power/COP values, and the horizontal axis shows the temperature of the output water. On the flow graphs, the vertical axis shows the flow rates, and the horizontal axis shows the temperatures of the output water. All graphs presented below are based on maximum output conditions, except for the COP graph, which is shown at the heat pump's optimal operating point.

Heating capacity [kW], 110 Hz

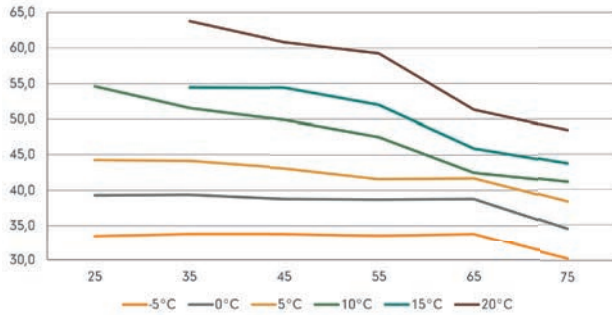

Cooling capacity [kW], 110 Hz

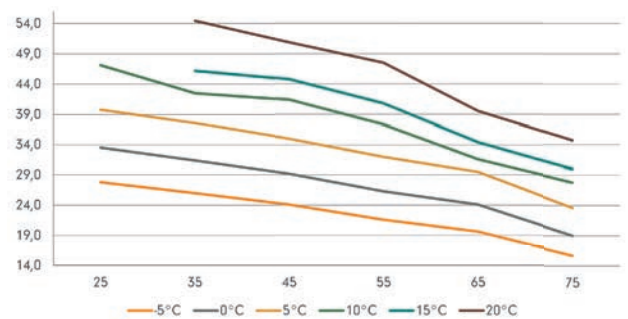

Input power [kW], 110 Hz

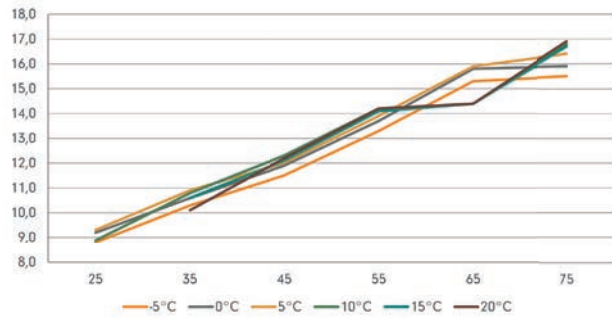

COP, 70 Hz

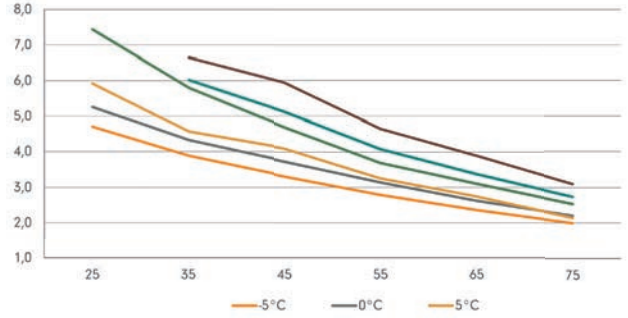

Max external pressure loss, Brine [kPa - l/s]

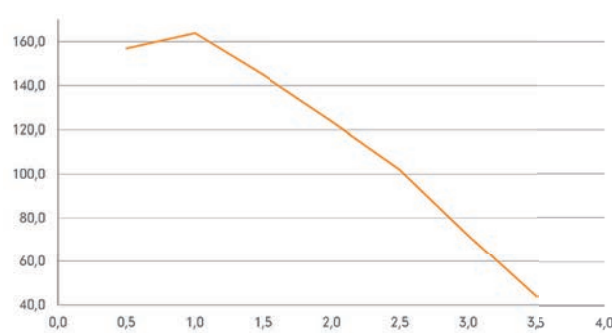

Max external pressure loss, Charge [kPa - l/s]

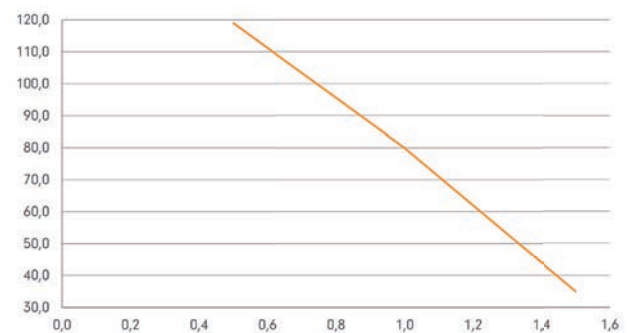

Brine flow dT3 [l/s]

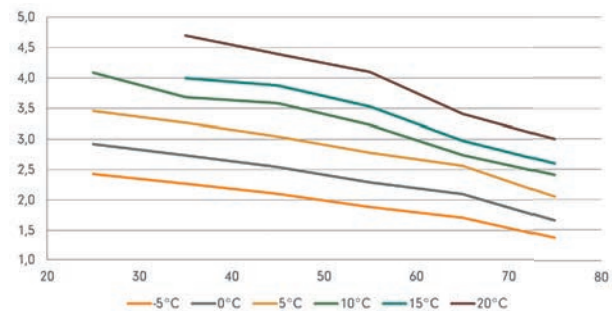

Charge flow dT8 [l/s]

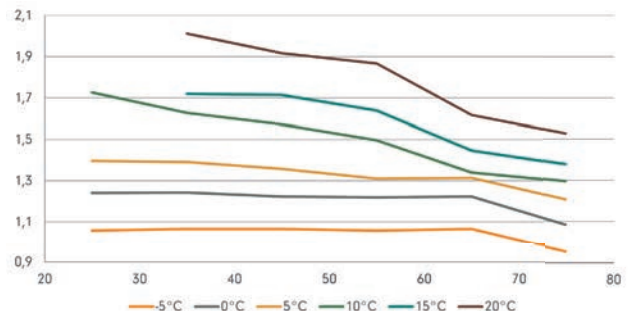

G-Eco Pro 120 performance graphs The following presents the performance of the G-Eco Pro 120 heat pump at various operating points. The graphs show information such as the heat pump's COP value outside the typical 0/35 or 0/55 points. In the power and COP graphs, the vertical axis represents the power/COP values, and the horizontal axis shows the temperature of the output water. The maximum pressure loss are shown on the vertical axis and the corresponding flow rates are shown on the horizontal axis. The graphs at the bottom show the flow rates of the collector and charge circuit under different conditions. The vertical axis shows the flow rates, and the horizontal axis shows the temperatures of the output water. All graphs presented below are based on maximum output conditions, except for the COP graph, which is shown at the heat pump's optimal operating point.

Heating capacity [kW], 70 Hz

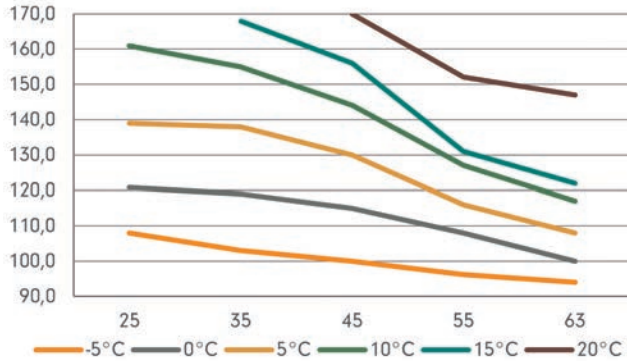

Cooling capacity [kW], 70 Hz

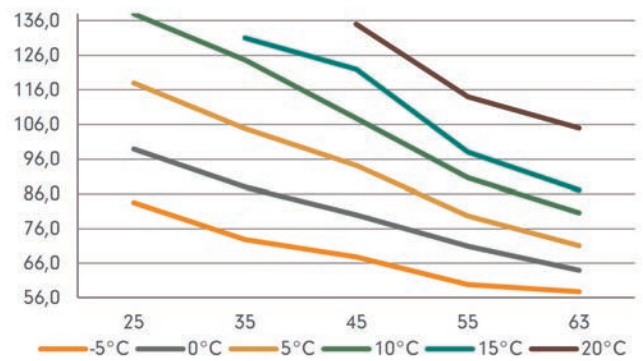

Input power [kW], 70 Hz

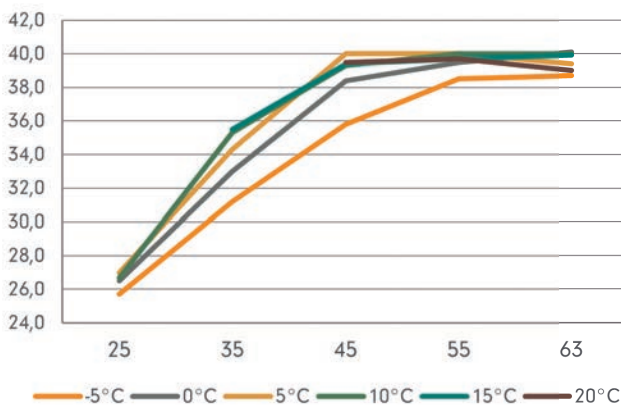

COP, 50 Hz

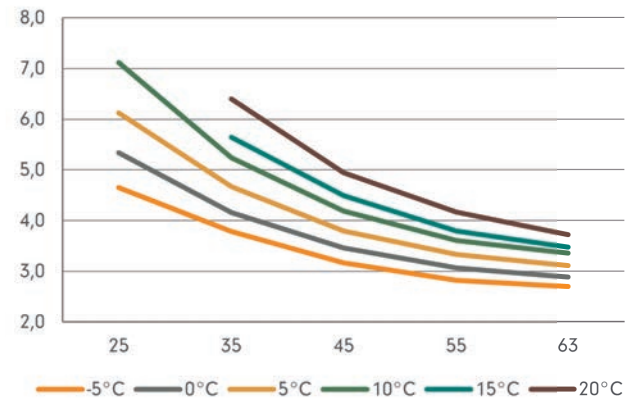

Max external pressure loss, Brine [kPa - l/s]

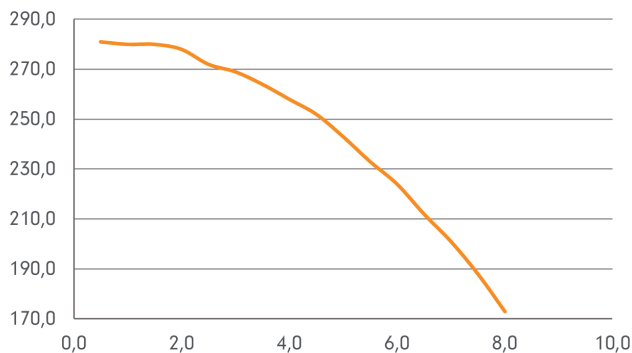

Max external pressure loss, Charge [kPa - l/s]

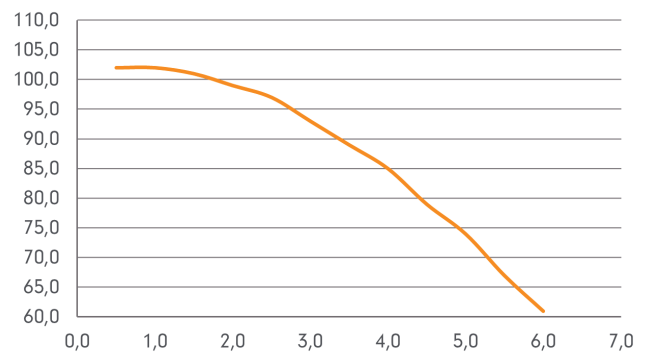

Brine flow dT3 [l/s]

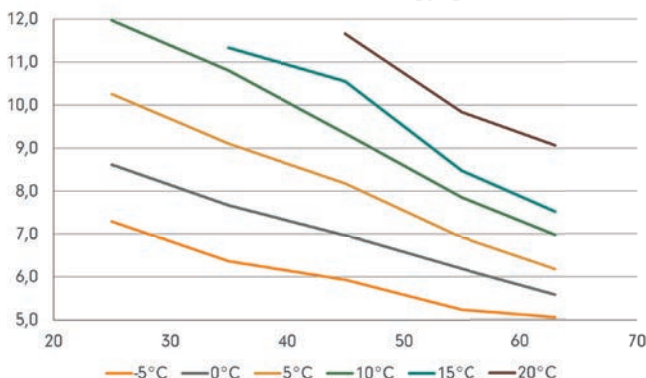

Charge flow dT8 [l/s]

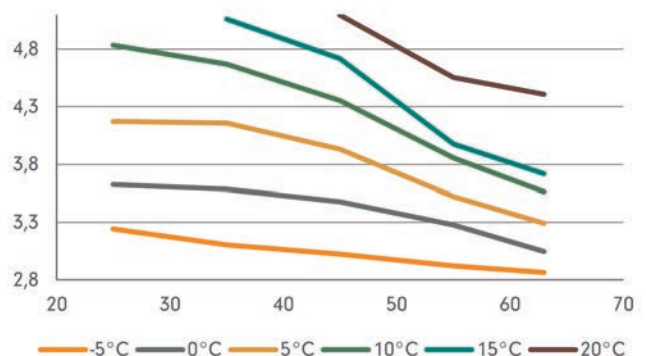

G-Eco Pro 120 HT performance graphs The following presents the performance of the G-Eco Pro 120 HT heat pump at various operating points. The graphs show information such as the heat pump's COP value outside the typical 0/35 or 0/55 points. In the power and COP graphs, the vertical axis represents the power/COP values, and the horizontal axis shows the temperature of the output water.

The maximum pressure loss are shown on the vertical axis and the corresponding flow rates are shown on the horizontal axis. The graphs at the bottom show the flow rates of the collector and charge circuit under different conditions. The vertical axis shows the flow rates, and the horizontal axis shows the temperatures of the output water.

All graphs presented below are based on maximum output conditions, except for the COP graph, which is shown at the heat pump's optimal operating point.

Heating capacity[kW], 70 Hz

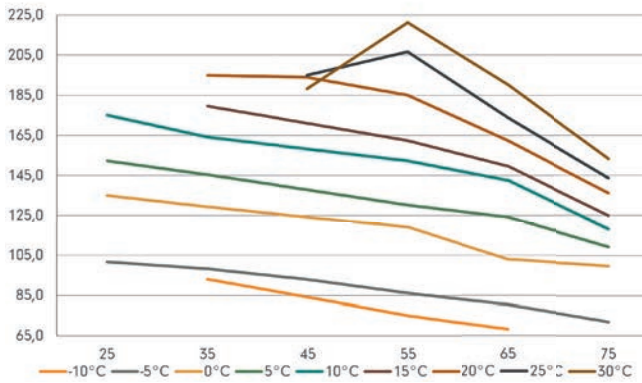

Cooling capacity [kW], 70 Hz

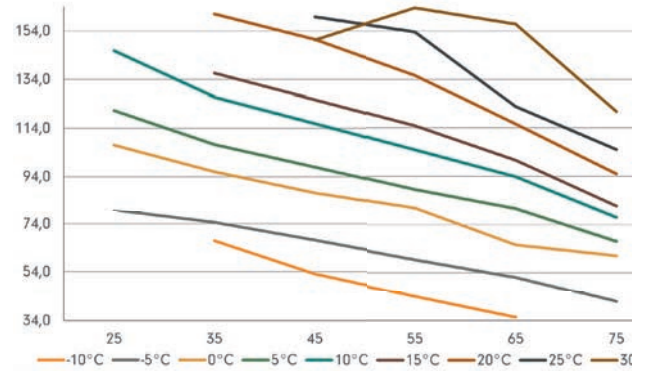

COP, 50 Hz

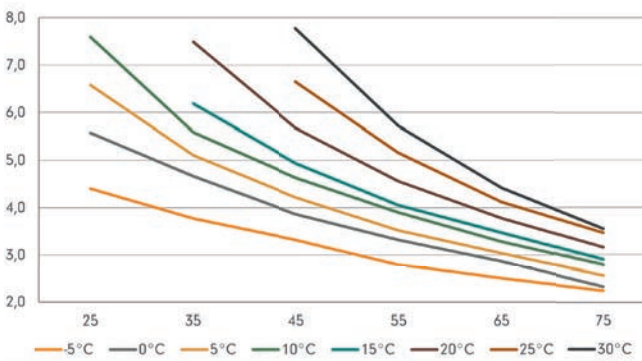

Brine flow dT3 [l/s]

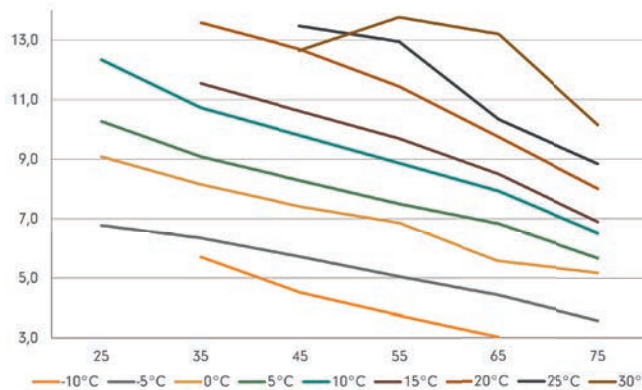

Charge flow dT8 [l/s]

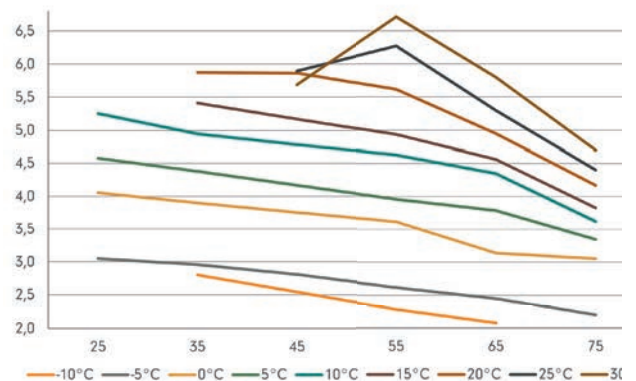

G-Eco Pro 120 HT performance graphs

Max external pressure loss, Brine [kPa - l/s]

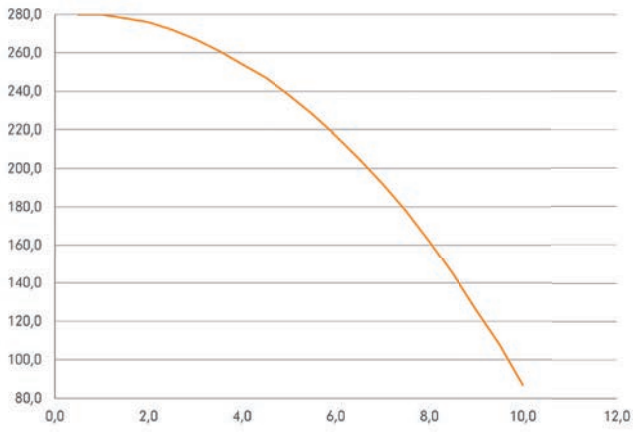

Max external pressure loss, Charge [kPa - l/s]

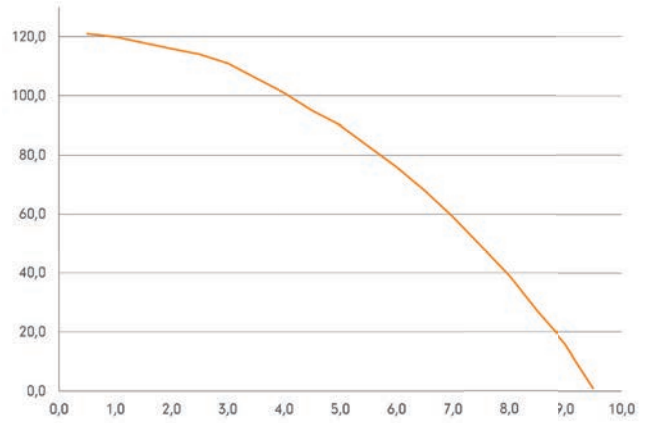

Internal evaporator pressure drop [kPa - l/s]

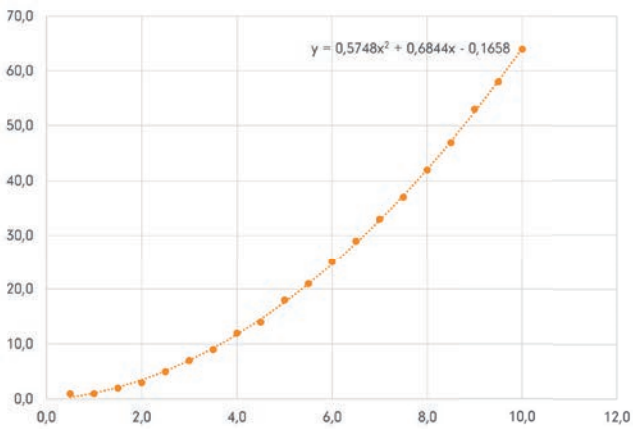

Internal condenser pressure drop [kPa - l/s]

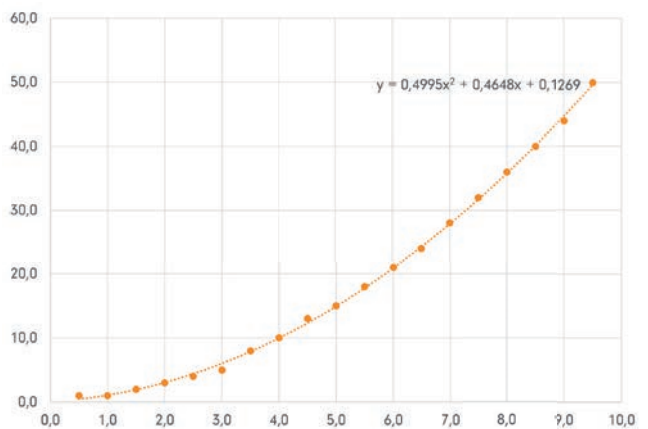

G-Eco Core 40 – Dimensions

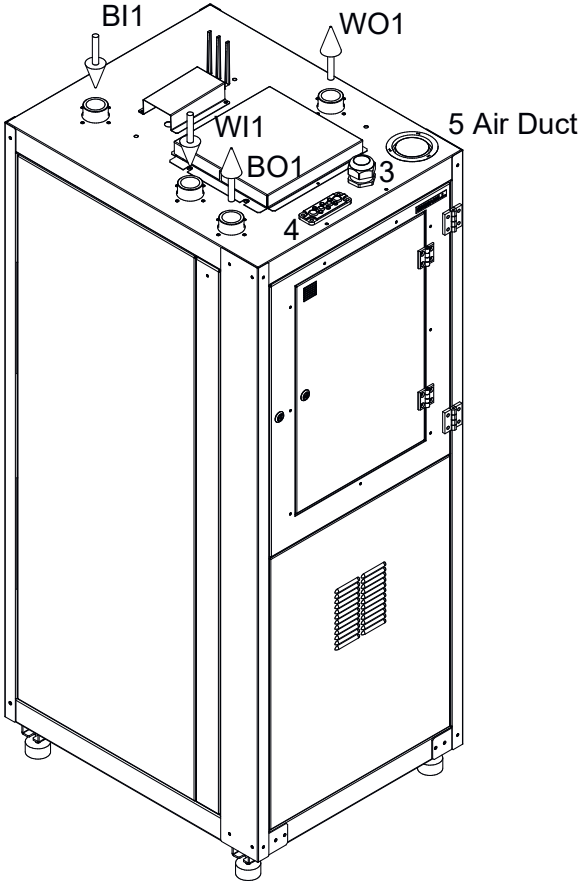
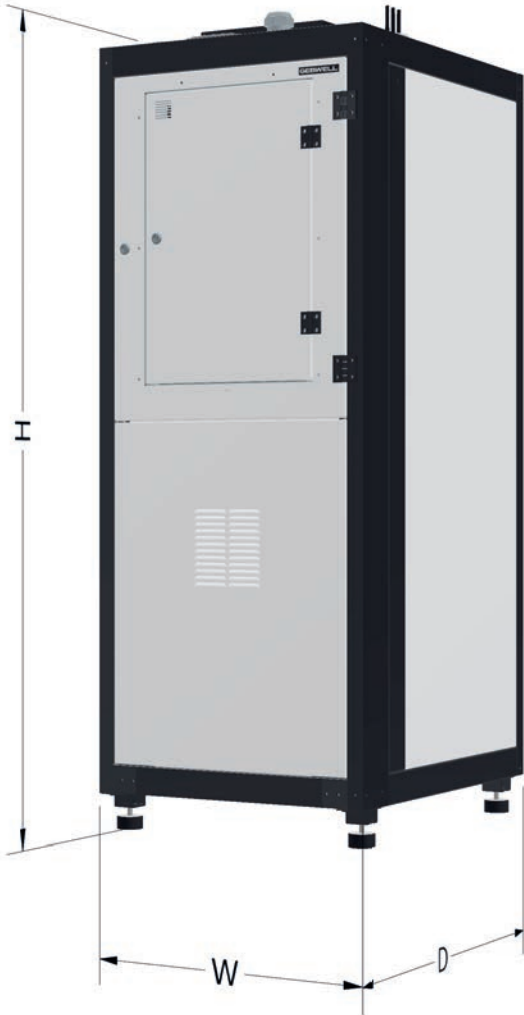

Dimensions	
D	850 mm
W	690 mm
H	1850 mm

Connections		Size
B01	Collector supply/out	G1 1/2" it
B12	Collector return/in	G1 1/2" it
WO1	Heating supply/out	G1 1/2" it
WI2	Heating return/in	G1 1/2" it
3	Lead-through, power supply	-
4	Multiple flange lead-through – sensors, control and data transfer cables	-
5	Ventilation	80 mm

G-Eco Core 40 - Installation dimensions

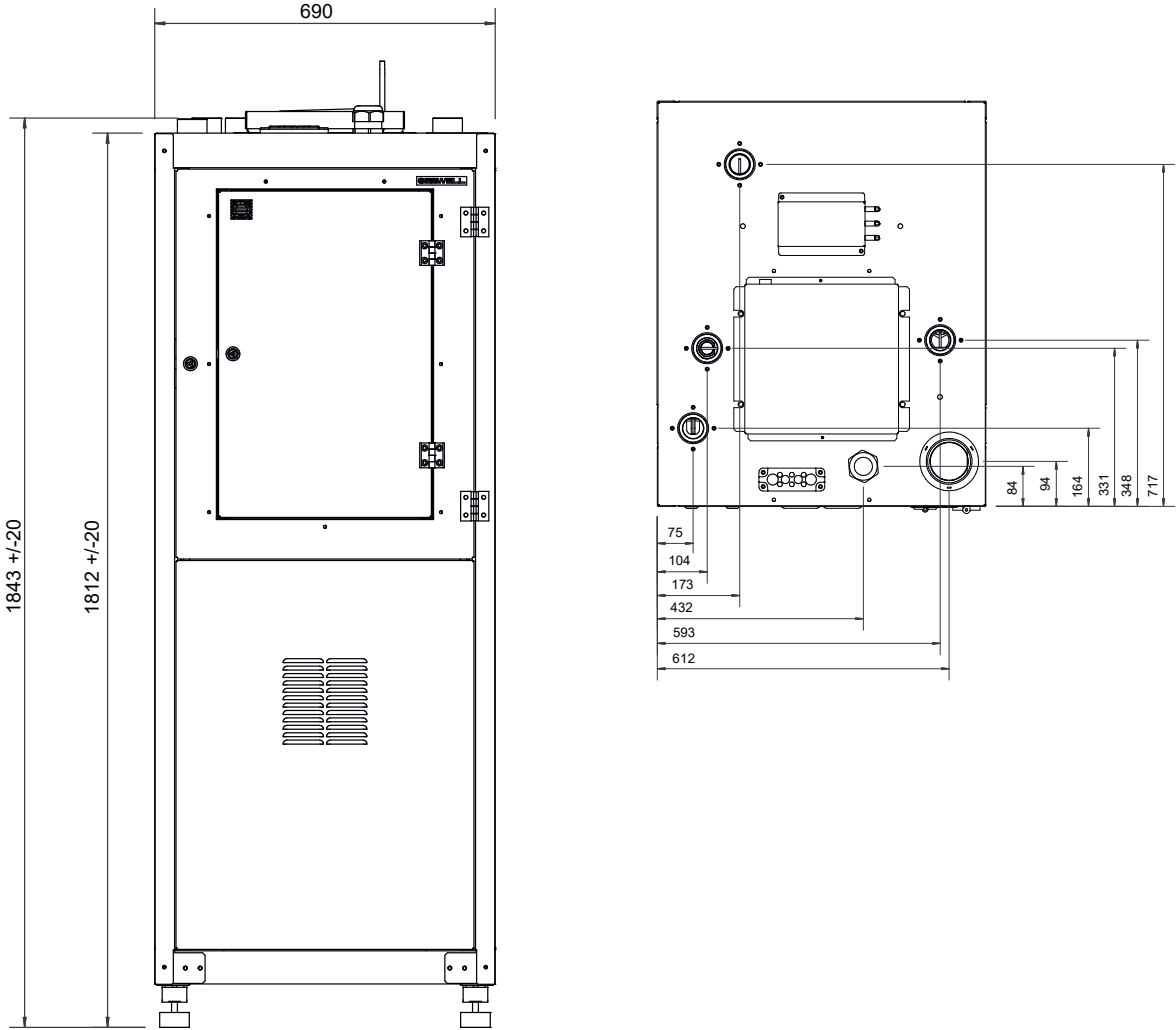

Service area required

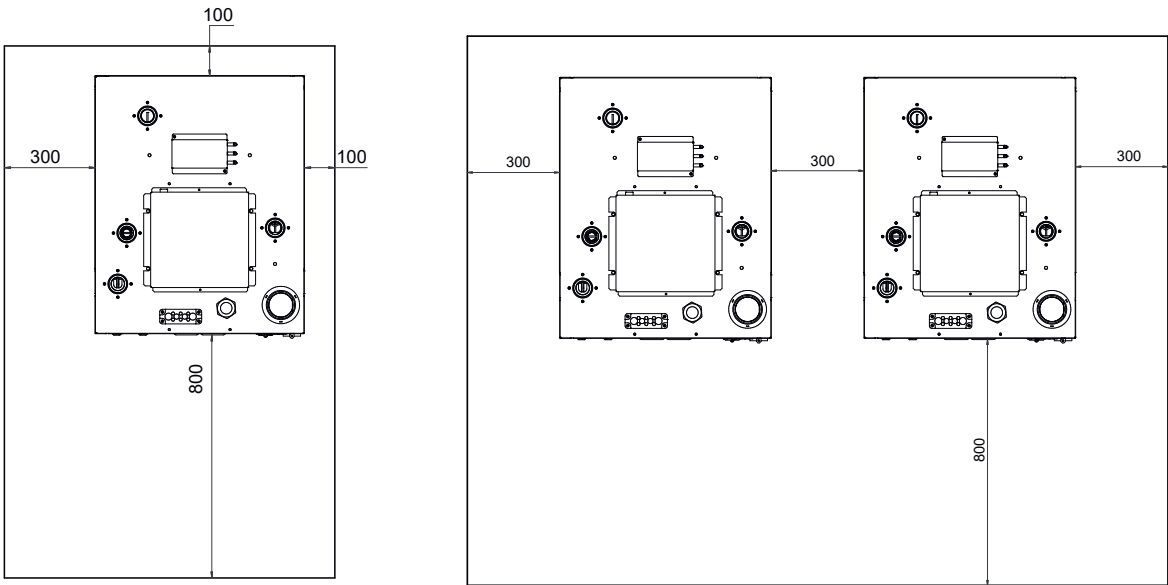

G-Eco® Pro – Dimensions

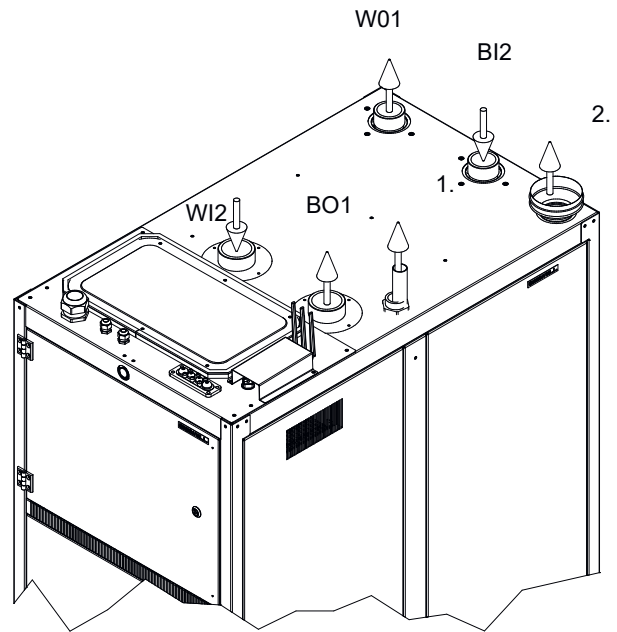

Dimensions		Connections		Size
D	1250 mm	BO1	Collector supply/out	G2 1/2" it
W	750 mm	BI2	Collector return/in	G2 1/2" it
H	1870 mm	W01	Heating supply/out	G2 1/2" it
		WI2	Heating return/in	G2 1/2" it
		1	Venting discharge	Cu 35 mm
		2	Ventilation	125 mm

G-Eco Pro – Installation dimensions

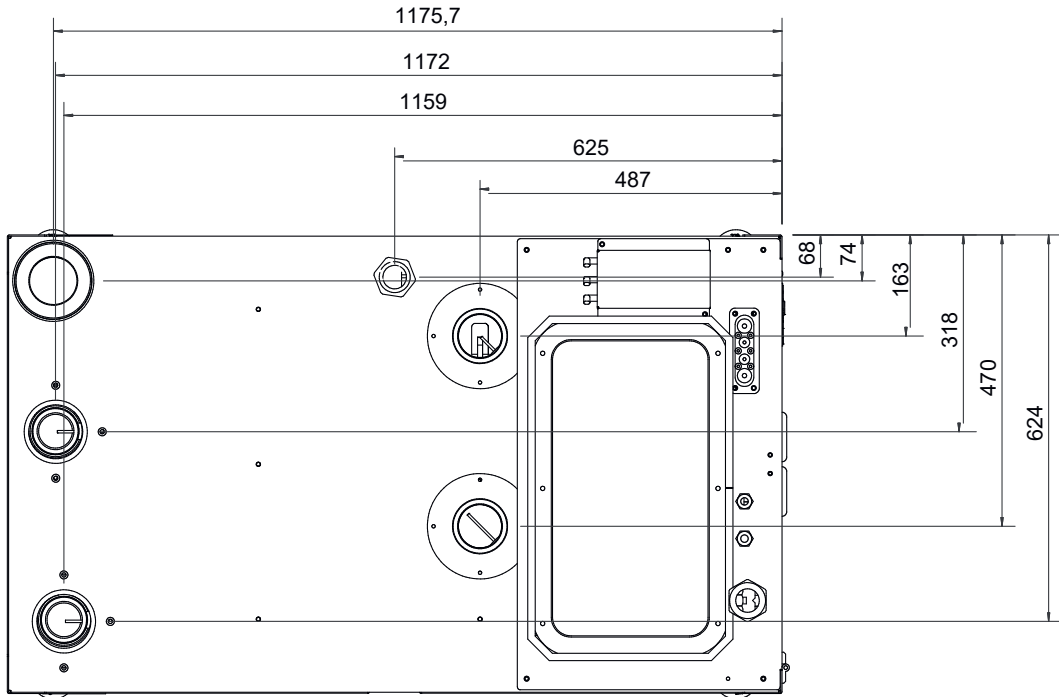

Service area required

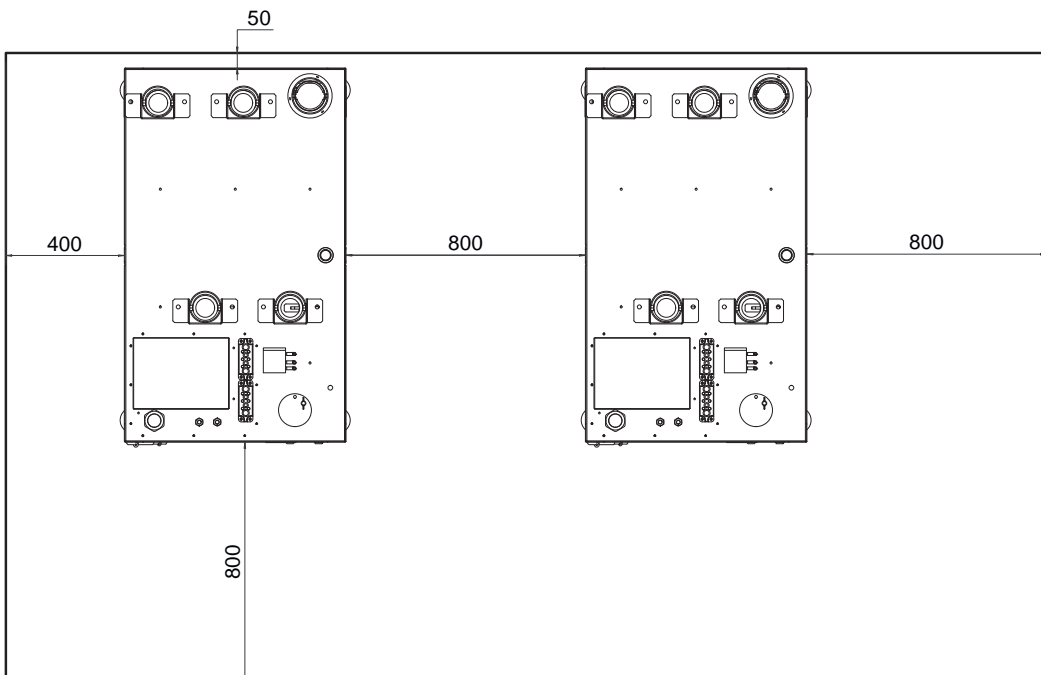

Gebwell Smart – purely smarter heating

Gebwell Smart brings property heating into the digital era – comfort, simplicity and substantial energy savings. Gebwell heat pumps connected to the Gebwell Smart cloud service offer a smart, energy-efficient solution for every property.

Constantly developing Gebwell Smart heat pumps

Every Gebwell Smart heat pump is linked to the Gebwell Smart cloud service at the factory. The IoT heat pump communicates with the cloud service over the entire warranty period and even after the warranty has expired, for as long as the remote access service is in force.

The cloud service uses the Internet of Things (IoT), and the service platform has first-rate information security. The data that the devices send to the cloud service is stored and used for the smart control of heat pumps, as well as for the continuous development of the device. A number of new features are currently in the pipeline to increase the user-friendliness of Gebwell Smart heat pumps and cut costs.

The Gebwell Smart heating system comes complete with data connections that only need to be set up before use. Gebwell Smart heat pumps include internet access, which means that the housing company does not need to acquire a separate internet connection for system control. Data communication fees for the Internet connection for the first two years for free.

Gebwell Smart Hub – showing the real-time status of the heating system 24/7

Gebwell Smart heat pumps are connected to the Gebwell Smart Hub by a cloud service. Maintenance companies can monitor heating systems and adjust the system settings remotely, thereby saving the cost of making a site visit.

The Gebwell Smart Hub also makes it possible to check any faults without visiting the site. The failure or maintenance needs of certain components can be identified even before an actual fault. The Smart Hub enables proactive maintenance by means such as monitoring the pressure of the network.

The Smart Hub administrator can manage user rights to the hub via the administration panel. The Smart Hub stores and displays measurement data from sites. The Smart Hub also allows adjustments to be made to the sites in areas such as the heating curve, domestic hot water temperature, the settings for the valves in the district heating substation (PID), the circulator pump settings, and the functions of electric immersion heaters.



From the Gebwell Smart Hub, you can remotely adjust, among other things

- General settings of the heat pump
- Heating and cooling settings
- Domestic hot water settings
- Auxiliary heat source settings

The price of Gebwell Smart heat pumps includes

- Data communication fees for the Internet connection for two years
- Browser-based Gebwell Smart Hub service for two years

Accessories for heat pumps

Gebwell Oy's product portfolio includes various types of accumulators to supplement the heat pump system, ranging from buffer tanks to special accumulators that can be customised as needed.

G-Energy buffer tanks

G-Energy buffer tanks can be used to increase the water capacity of a heating system. A higher water capacity ensures a steady and sufficient flow and improves the operation and efficiency of the heat pump. A higher water capacity also extends the duty cycles of the compressor, as well as its service life.

G-Energy buffer tank

- Available as 501-, 750- and 1000-litre models, with DN50 and DN65 connections and in 3 or 6 bar pressure classes.
- The accumulator tank is made out of steel primed and pressure tested.
- The insulation is made out of die-cast closed-cell urethane.
- As standard, the insulation is made out of detachable segments, which are easy to detach and reattach.
- The outer surface of the insulation segments is made out of painted steel plate with a protective coating.
- At the bottom of the accumulator tank there is a steel base to ease hauling. The steel base has two parts, the lower section can be removed before installation. When lowered, the height of the 501-litre accumulator is 90 mm, the 750-litre accumulator 130 mm and the 1000-litre accumulator 150 mm lower compared to the standard.



G-Energy 300 buffer tank

- Module-sized 275-litre buffer tank.
- Buffer tanks even out the starting intervals of heating equipment and so improve the equipment's durability. For example, a buffer tank can reduce the number of times a heat pump's compressors need to be started.
- The accumulator tank is made out of stainless steel, and the surface plate is a powder coated steel plate.
- The insulation used in the accumulator consists of 100-mm thick die-cast CFC-free polyurethane. The die-cast polyurethane also acts as the accumulator's frame, making it sturdy.
- The levelling feet on the base make installation easy.
- The SV model has two electric immersion heater connections that can accommodate a 10-kW electric immersion heater at maximum. Electric immersion heaters are ordered separately.

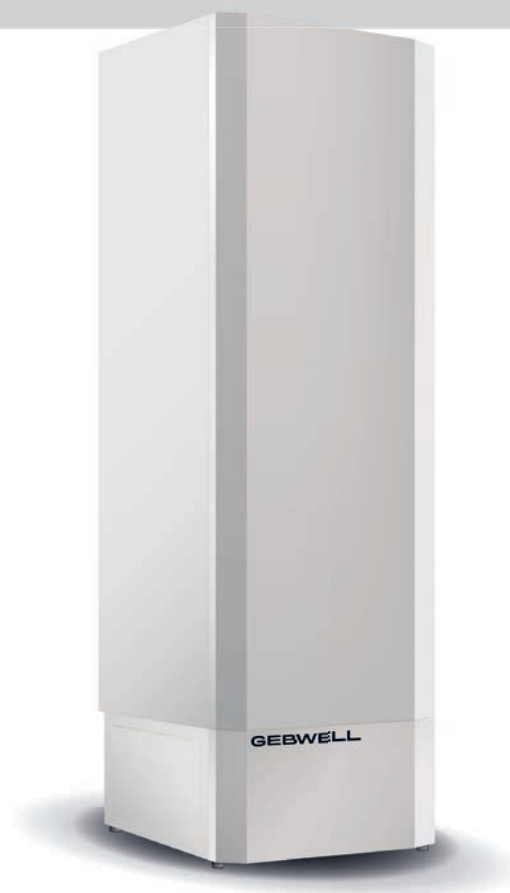

G-Energy DHW buffer tank

- Gebwell G-Energy DHW is a stainless steel buffer tank for hot domestic water. The G-Energy DHW buffer tank contains hot domestic water ready for use.
- The G-Energy DHW is especially well suited as a part of heat pump systems for real estate that take advantage of superheating technology.
- The G-Energy DHW tank is made of stainless steel (EN 1.4521), with a design pressure of 1.0 MPa (10 bar).
- The tank is insulated with 95 mm Neopor insulation and encased in a polypropylene cover.
- The buffer tank features a vertical coil and two connections for electric heaters.



G-Energy SV buffer tank

G-Energy SV buffer tanks feature connections for electric immersion heaters.

- The 501-litre models are equipped with three connections for electric immersion heaters, the 750-litre models with three or six connections, and the 1000-litre models come with three, six or eight electric immersion heater connections.
- According to need, the accumulator is equipped with electric immersion heaters to ensure sufficient heating and domestic hot water.
- Equipping the accumulator with electric immersion heaters enables, for instance, a wood-heated house to be heated with electricity during a holiday trip. Electric immersion heaters are ordered separately.



G-Energy PW buffer tank

G-Energy PW buffer tanks are suitable for domestic water preheating and heating system buffer tanks.

- In properties with a heat pump, the preheating of domestic water enables the domestic hot water to be heated more energy efficiently and improves the sufficiency of domestic hot water.
- Two flanges for domestic hot water preheating coils. The 501-litre buffer tanks are equipped with three connections for electric immersion heaters, and the 1000-litre models come with three or six electric immersion heater connections. Coils and electric immersion heaters are ordered separately.

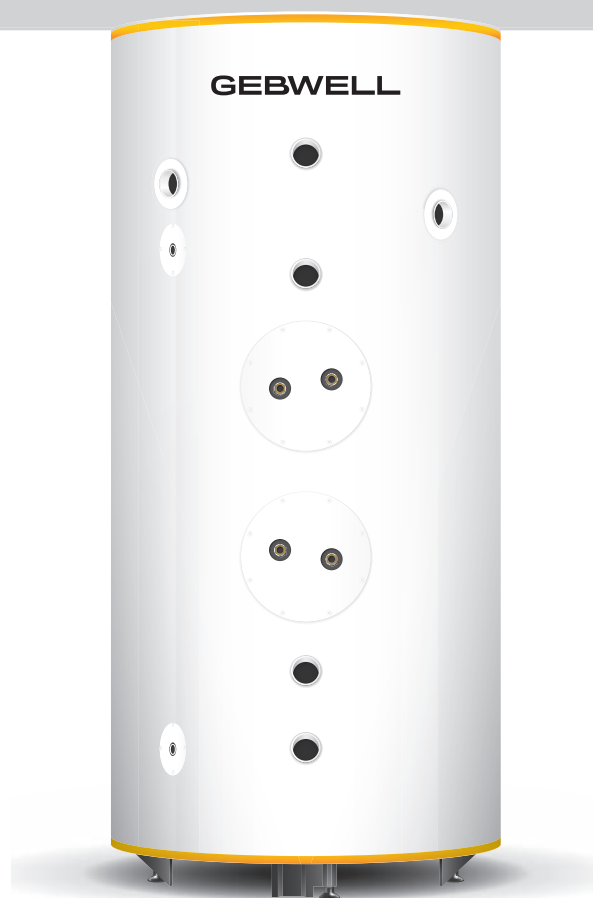

G-Energy Cooling buffer tank

G-Energy Cooling is a buffer tank developed for cooling systems.

- Can be used as a buffer tank for, e.g., water coolers and other mechanical cooling systems. Buffer tanks even out the conditions between the start-up times of cooling equipment and reduce the number of times compressors need to be started.
- Available as 501-, 1000- and 2000-litre models and in 3 and 6 bar pressure classes.
- The tank is made out of steel, primed and pressure tested.
- 19-mm cellular rubber insulation
- At the bottom of the accumulator tank there is a steel base to ease hauling. The steel base has two parts, the lower section can be removed before installation. When lowered, the height of the 501-litre accumulator is 90 mm, the 750-litre accumulator 130 mm and the 1000-litre accumulator 150 mm lower compared to the standard.



G-Energy Coil buffer tank

Equipped with coils, G-Energy Coil is suitable for heating domestic hot water together with a heat pump.

- Available as 501-, 750- and 1000-litre models and in 3 and 6 bar pressure classes.
- Depending on the size, the accumulator includes one to five 25-metre-long coils. The 501-litre model is equipped with one or three coils. The 750-litre models are equipped with one to four coils and 1000-litre models with one to five coils.
- The 501- and 1000-litre models are equipped with two connections for electric immersion heaters and the 750-litre model is equipped with three connections. Electric immersion heaters are ordered separately.
- Also available as a low-height model. The low-height model is 2,000 mm tall with the insulation in place, and 1,980 mm with the insulation detached.
- At the bottom of the accumulator tank there is a steel base to ease hauling. The steel base has two parts, the lower section can be removed before installation. When lowered, the height of the 501-litre accumulator is 90 mm, the 750-litre accumulator 130 mm and the 1000-litre accumulator 150 mm lower compared to the standard.



G-Energy Custom accumulator tank

- A special accumulator designed for installations not suitable for our standard models.
- Equipped with flexible features, the special model is fully customisable. The customer can select the capacity, material, pressure class and insulation material of the accumulator.
- The size of connections and the number and place of connections and sensor pockets can also be customized.
- The special accumulator is available either with or without a bulkhead.



Collector valve group

Valve group makes the filling and the venting of collector easy. In addition, the dirt filter removes the possible dirt particles in the liquid circulation.

Valve group is meant as accessory for all Gebwell heat pumps.

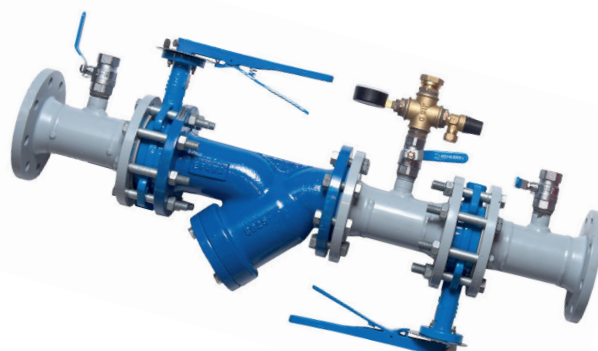

Heating control group

With heating control group the adjusting of heating network is easy

Connecting the heating control group to the heating network is easy and effortless. By connecting another control group to heat pump, you can heat damp spaces all-year round regardless of other spaces' heating needs.

Heating control group is meant as accessory for all Gebwell heat pumps.

Control group includes heating pump, shut-off valve, control valve with actuator, dirt filter, needed sensors, electric cables, hangers and wall mounting rails.



A cleaner future and greater everyday convenience are of interest.

Contact us, and together we will find a solution for Your project from our extensive product range.

GEBWELL
PURE HEAT

Patruunapolku 5, FI-79100 Leppävirta, FINLAND

+358 20 1230 800 | info@gebwell.fi

gebwell.com



Gebwell Ltd. reserves the right for changes.



Gebwell Ltd. and its partners won the most important recognition in the European heat pump industry: the Next Generation Heat Pump award!

